

OPERATOR MANUAL

Combo Belt Conveyor

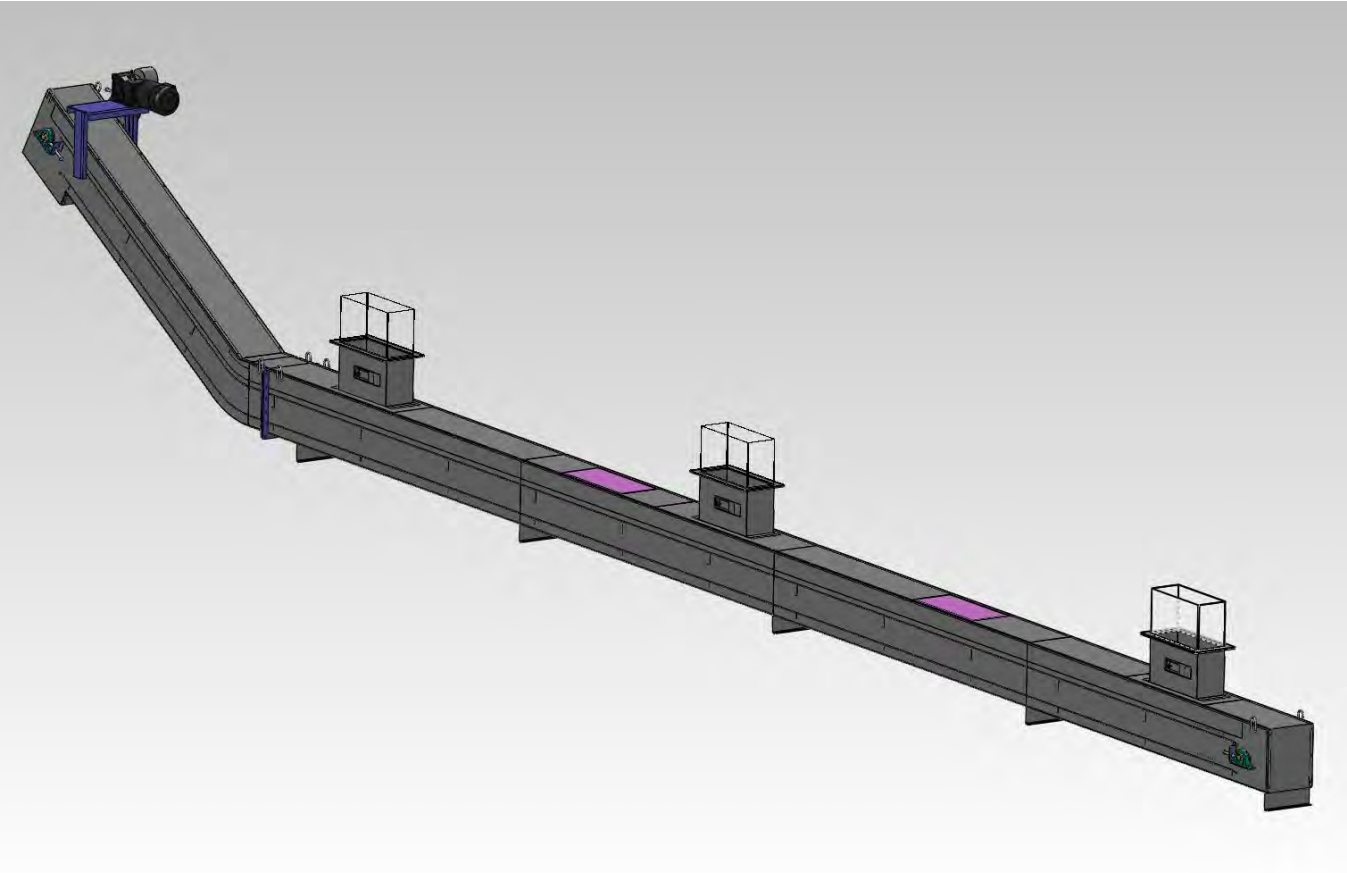

WARNINGS

- THIS CONVEYOR IS DESIGNED FOR A SPECIFIC APPLICATION.
- CHECK FRAME AND METAL BELT FOR DAMAGE DURING SHIPMENT.
- READ THE MANUAL FOR PROPER INSTALLATION AND START-UP.
- CONVEYOR MUST BE LEVEL AND PLUMB FOR PROPER OPERATION.
- CHECK ALL DRIVE COMPONENTS FOR ALIGNMENT AND TENSION.
- CONTROL BOXES AND OTHER ATTACHMENTS MUST BE MOUNTED WITH EXTREME CARE SO AS NOT TO INTERFERE WITH CONVEYOR OPERATION
- VERIFY ALL WIRING FOR CORRECT VOLTAGE, CYCLE & AMPERAGE
- PROPER CHAIN TENSIONING IS REQUIRED AT INSTALLATION, AND WHEN IN USE FOR 30-45 DAYS, A READJUSTMENT SHOULD BE PRE-FORMED.
- LOCK OUT AND TAG OUT POWER SOURCE PRIOR TO ANY ADJUST-MENTS OR MAINTENANCE.
- KEEP HANDS AWAY FROM CONVEYOR WHEN POWER SOURCE IS NOT LOCKED OUT.
- DO NOT STEP ON CONVEYOR.

DANGER

Use OSHA Lockout/Tagout procedures before performing any inspections, adjustments, or maintenance procedures on this equipment. Failure to follow OSHA required procedures at all times without exception could result in severe injury and is against Federal workplace safety laws.

Table of Contents

DESCRIPTION	5
General	5
Conveyor Casing Construction	5

Drive Arrangement	5
Tail End and Take up	6
Conveyor Medium	6
Overload Devices	7
INSTALLATION	8
START UP INSTRUCTIONS	9
SERVICE AND MAINTENANCE	9
Electric Controller	9
Speed Reducer and Motor	10
Inspection and Adjustment of the Headshaft	11
Installation of Belt	13
LUBRICATION	13
Grease Lubrication	14
Oil Lubrication	14
TROUBLESHOOTING	15

IMPORTANT

- 1. Refer to WARNINGS on the inside front cover.**
- 2. Review the Lubrication Section of this manual.**
- 3. Variations in design of this conveyor may not be covered in this manual. Call Jorgensen Conveyors if additional information is required**
- 4. Must be sure the conveyor is turned on and operating satisfactorily before loading the conveyor.**

CAUTION – the conveyors from JORGENSEN CONVEYORS may be operated only by the persons who are properly trained in operation of electrical machines and equipment and familiar with this Operation and Maintenance Manual.

DESCRIPTION

General

This manual encompasses the specific design of Jorgensen's combo belt conveyor intended for use only with recycled paper pellets.

Conveyor Casing Construction

The conveyor casing is designed with formed side frames and a channel spacer. The channel spacer is welded in connecting the frames. Top and bottom covers are bolted in place for removal during clean out. Tracks are welded onto the inside of the casing sidewalls. The tracks act as supports and guides for the conveyor chain to which the conveyor belt is fastened.

Drive Arrangement

- This conveyor is driven by gearmotor. The gearmotor transmits power through the roller chain. There is a torque limiter mounted directly onto the headshaft. The headshaft has conveyor chain sprockets mounted to it, which drive the combo belt. (Figure 1)

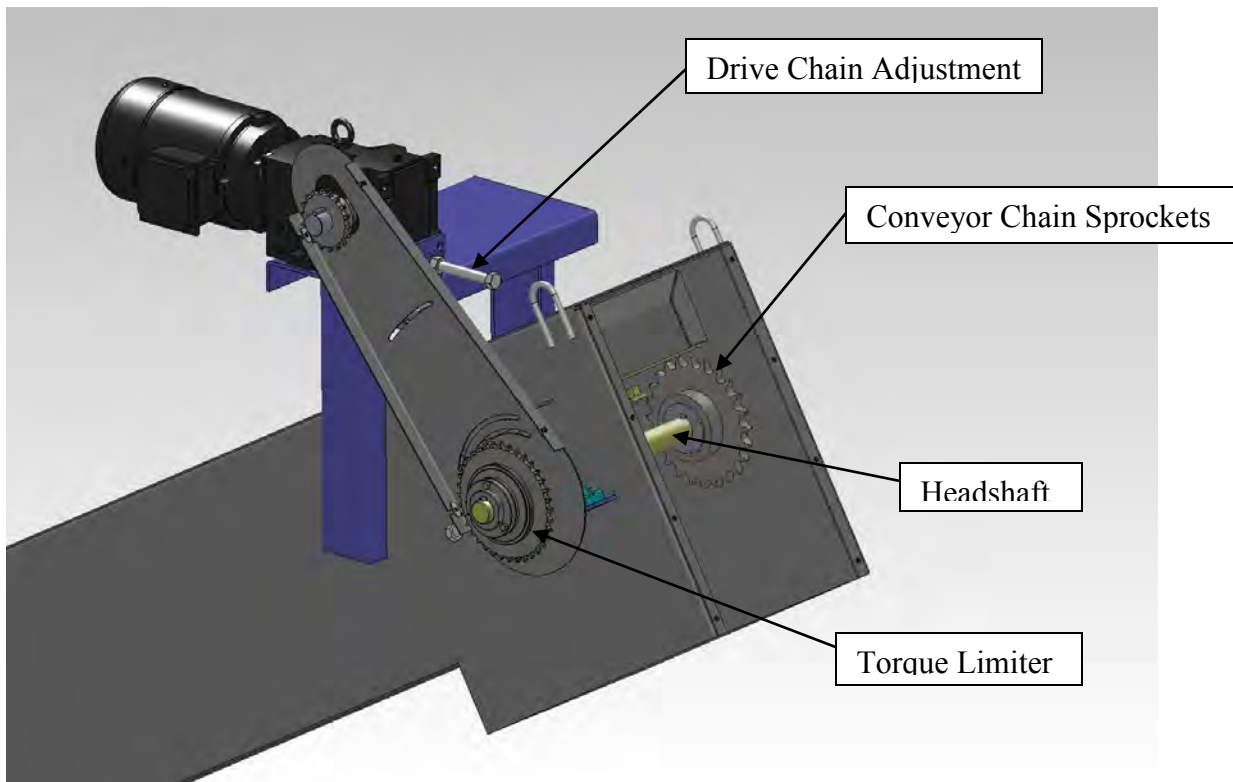

Figure 1 – Drive Arrangement

Conveyor Tail End & Take up

- The tail end consists of a tailshaft supported by two pillow block bearings. The pillow block bearings are mounted to angle brackets which have slots for taking up the slack of the conveyor chain with adjustment bolts. The conveyor sprockets are mounted on a shaft where one is keyed and set screwed while the other is free floating. This keeps the tailshaft arrangement from binding due to any conveyor chain irregularities. (Figure 2)

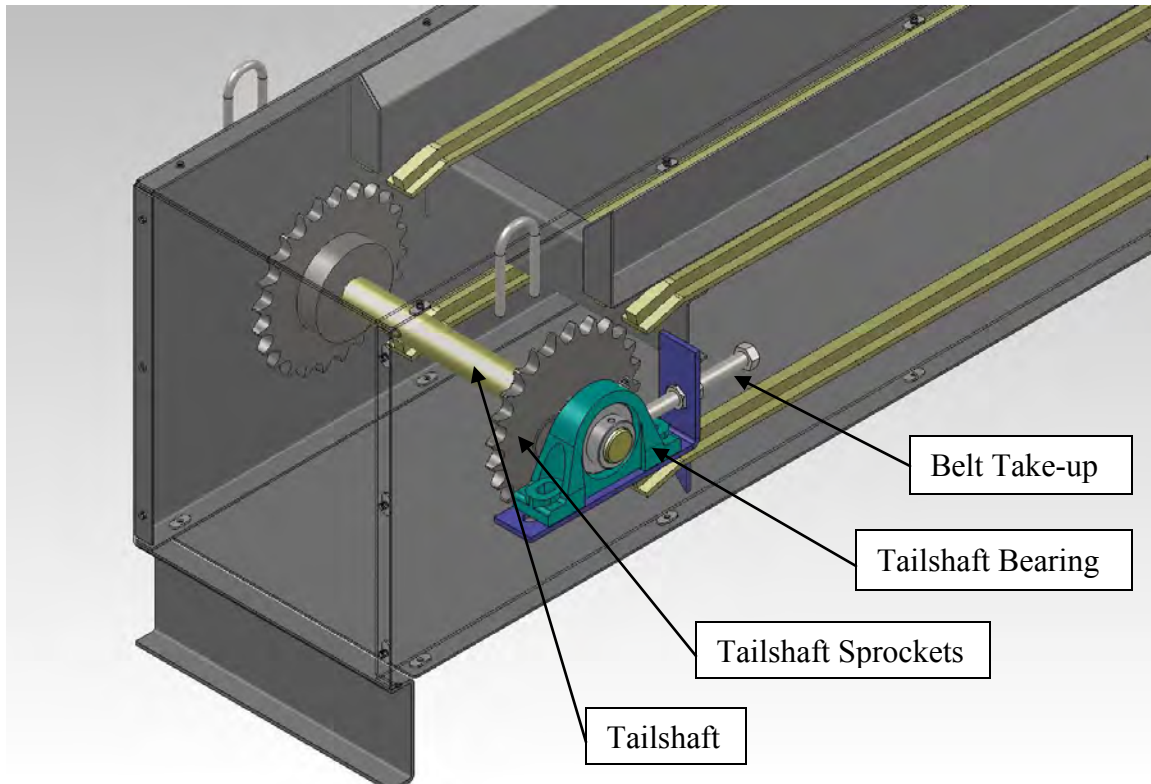

Figure 2 – Tail End and Take up

Conveyor Medium

- The combo belt design consists of using two strands of No. 80 roller chain connected together with a spreader bar welded to each strand at 12.00” centers. The spreader bar has weld nuts for fastening the belt to it. The belt is a 2-ply SBR rubber. There are also cleats fastened to the spreader bars at 24.00” centers. (Figure 3)

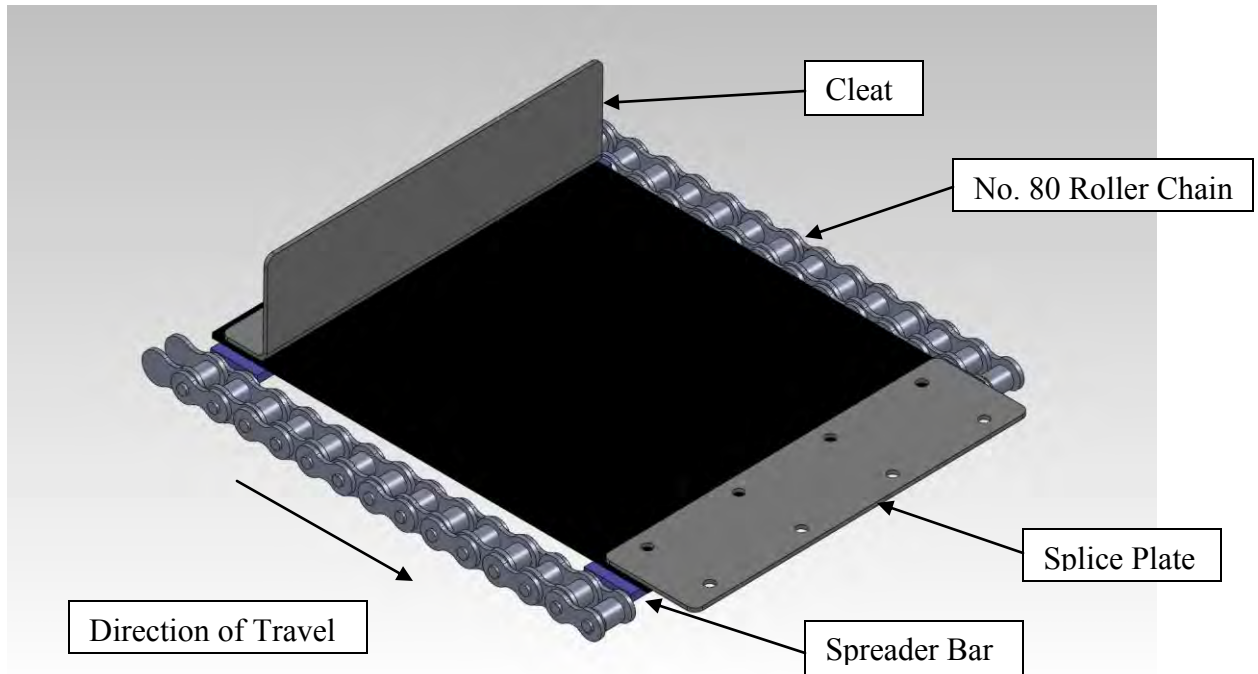

Figure 3 – Conveyor Medium

OVERLOAD DEVICE

This conveyor is equipped with a Morse torque limiter. This unit is designed to limit the torque transmitted by the drive system when the torque exceeds a preset value as a result of overload, shock load, or jamming of the conveyor. Adjustable spring pressure determines overload setting and automatically reengages drive when overload condition subsides. (Figure 4)



Figure 4 – Morse Torque Limiter

INSTALLATION

The conveyor unit is shipped in two pieces with the belt removed. In this case it is customer's responsibility to assemble the conveyor and install the belt. As a safety precaution, be sure to use the proper lifting device to unload the unit.

- Uncrate the unit carefully, and inspect for damage that may have occurred during transit. If damage has occurred, notify the carrier immediately. Review this manual in its entirety before beginning installation. If you have any questions, contact Jorgensen Conveyors.
- This unit has been lubricated, run-in, and tested in our facility. However, transportation can affect factory settings. Verify that all the bolts on this unit are still tight. Also check the drive chain tension. If necessary, adjust the unit as directed in this manual.
- Check for, and remove, any loose material in the unit, especially from the base of the load section of the unit.
- An assembly drawing has been provided. Refer to this drawing and use the following as a guide on how to proceed with installation.
- Move head and tail sections into position. Using the hardware provided, bolt the two flanges together insuring sections are properly aligned. Remove the top cover, and check that tracking aligns at section joint.
- Clamp the chutes provided to the discharge of the existing extruder. Match mark and drill holes in chutes supplied. When completed bolt together.
- Aligned chutes with cutouts in the top covers, and weld as required. There are two cover pieces per chute. Weld cover pieces together when welding in chute. See drawing 42-3437.
- Touch up of finish may be done with paint supplied by Jorgensen Conveyors, Inc.
- Finally install the belt. Use guidelines found on page 13 for belt installation.
- Connect power and controls as required.

START UP INSTRUCTIONS

CAUTION: Before connecting the conveyor to a power source and starting, inspect the drive, discharge, and belt areas of conveyor for foreign objects which may cause personal injury or damage to equipment.

Insure all maintenance and necessary adjustments have been completed.

Insure all maintenance and operational personnel are clear of the equipment.

Failure to observe these precautions may result in personal injury or damage to equipment.

Initially (and after prolonged shutdown) be sure that the conveyor drive has been correctly wired and that all covers and shrouds are in place.

If the conveyor has been shut down for a prolonged period, proceed as follows:

- Check for correct tensioning of the conveyor belt, as described later under “Belt Tension Adjustment.”
- Verify that all bolts in the take-up assembly and drive unit are tight.
- Be sure that the roller chain on the indirect drive unit has been properly lubricated (brushed with light-weight oil).

If gearmotor is powered through a variable frequency drive (VFD), start conveyor at a slower speed, observing operation. Gradually increase the speed until reaching determined operational speed. Allow unit to run 15 minutes, confirming trouble-free operation before placing unit in service.

If a VFD is not being utilized, start unit and allow it to run 15 minutes, confirming trouble-free operation before placing unit in service

SERVICE AND MAINTENANCE

The conveyor requires regular maintenance, including lubrication, in order to sustain trouble-free operation.

CAUTION: Before any maintenance is performed, insure all sources of power, air and/or electric, have been disconnected from the equipment and that appropriate lock-out /tag-out procedures have been put into effect.

SPEED REDUCER AND MOTOR

Indirect Drive Units

Optionally, conveyors may be equipped with a roller chain in conjunction with a speed reducer. These may require periodic lubrication, and the roller chain may require occasional adjustment.

Indirect Drive Reducer Lubrication

The speed reducer used in the indirect drive system may require periodic lubrication. Recommended lubrication oil is shown in gearmotor manufacturer's manual. For unusual temperatures, or to use synthetic oils, contact the manufacturer.

Roller Chain Adjustment

1. Check sprocket alignment using a straight edge or taut cord stretched across the faces of the drive sprocket and the driven sprocket. The tolerance is ± 0.5 degrees or 3.5 mm per 0.3 m (1/8" per foot).
2. Check sprockets and components. Be sure that all are in good condition and free from contamination. The roller chain should be lubricated and free from chips or turnings.
3. Check roller chain tension. Deflection of the span shown is in Table 1.
4. Be sure all setscrews, bolts, and nuts are tight.
5. Lubricate the roller chain by brushing with lightweight oil.

Table 1 - Deflection of Roller Chain between Sprockets.

DRIVE CENTER	12.7 cm 5"	25.4 cm 10"	38.1 cm 15"	50.8 cm 20"	76.2 cm 30"	101.6 cm 40"	152.4 cm 60"	203.2 cm 80"	254 cm 100"
Horizontal	.64 cm .25"	1.27 cm .50"	1.91 cm .75"	2.54 cm 1.00"	3.81 cm 1.50"	5.08 cm 2.00"	7.62 cm 3.00"	10.16 4.00"	12.7 cm 5.00"
Vertical	.31 cm .12"	.64 cm .25"	.97 cm .38"	1.27 cm .50"	1.91 cm .75"	2.54 cm 1.00"	3.81 cm 1.50"	5.08 cm 2.00"	6.35 cm 2.50"

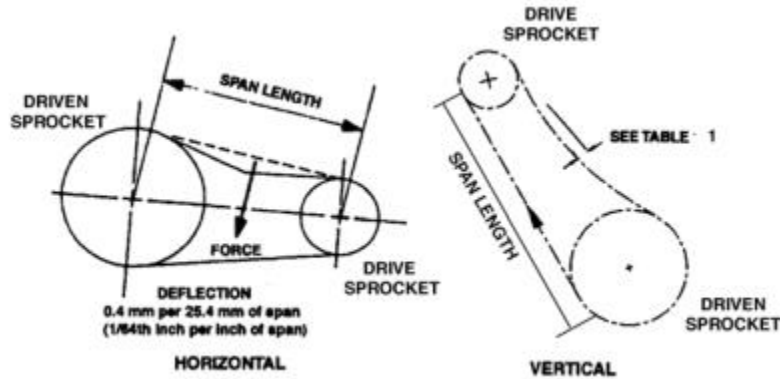

Diagram of Table 1 - Deflection of Roller Chain between Sprockets.

INSPECTION AND ADJUSTMENT OF THE HEADSHAFT

WARNING: Failure to follow safety procedures can cause personal injury. Disconnect all electrical power from the conveyor unit before removing the headshaft cover or servicing the headshaft assembly. Follow guidelines for appropriate lock-out /tag-out procedures.

1. Lock out and tag out electrical power to the conveyor unit.
2. Remove any drive system covers.
3. Move the drive motor/speed reducer assembly on its adjustment screws to relieve tension on the roller chain.
4. Disconnect the master link from the roller chain and remove the chain from the headshaft drive sprocket. Remove covers, as necessary, to expose the headshaft.
5. The headshaft can be now be inspected as follows:
 - A. If the belt runs against the sides of the conveyor or wanders from side to side:
 - a. Measure the distance between the headshaft sprocket face (or chain face) and the inside of the sidewall on both ends of the shaft to verify that the drag chain or metal belt is centered in the discharge section. If not, proceed as follows:
 - Move the shaft and sprocket towards the side of the machine having the greatest clearance.

- Measure the distance between the chain face (or sprocket face) and the inside of the sidewall. Be sure that the sprockets are centered (distance is equal for both sides).
 - Retighten the bearing block setscrews.
- b. If the belt still runs against the side of the conveyor, or if the chain or belt “climbs” the sprockets:
- Measure the distance between the bearing and the front edge of the sidewall (Figure 6.) to verify that the headshaft is not skewed.

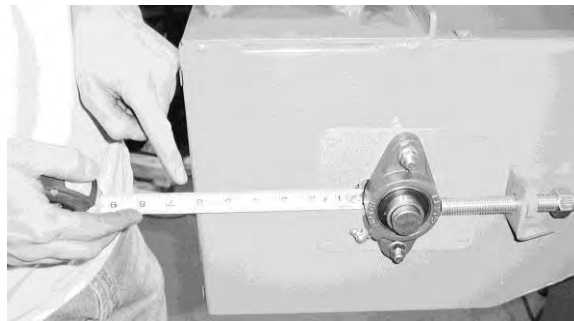

Figure 6 - Checking for Headshaft Skew

- If the shaft is skewed, loosen the bearing block mounting carriage bolts on the lagging side and, using the take-up device, balance the position of the headshaft in the discharge section.
 - Tighten the bearing block bolts.
- c. If the drag chain or the metal belt climbs the sprockets even after steps (a) and (b) have been completed. The belt tension may be too loose. Check belt tension as described under “Belt Tension” below.
- B. If the driven sprocket turns but the headshaft does not, check the drive key to ensure that it is not sheared.
- C. If the headshaft turns, but the chain does not move, inspect the headshaft sprocket keys. If the pins or keys are damaged, refer to “Removal of Headshaft Assembly” below.
- D. If the headshaft has lateral movement in the bearings: Check the headshaft-bearing mounting carriage bolts for tightness (Figure 4). If either is loose, proceed as follows:
- Adjust the headshaft so that the chain equal distant between the chain and the inside of the side plate on each side.

- Tighten the headshaft-bearing mounting carriage bolts.
- E Headshaft is seized and does not rotate: refer to “Removal of Headshaft” below.
6. Reinstall the roller chain, and adjust tension.
 7. Reinstall all covers and shrouds.
 8. Apply electrical power.

INSTALLATION OF BELT

Installing the belt assembly is essentially the reverse procedure discussed under “Removal.” Proceed as follows:

1. Be sure that the headshaft is pushed all the way back.
2. Feed one end of the combo-belt assembly into the lower run of the conveyor casing through the discharge section. Be sure that the cleats face downward; i.e. toward bottom of conveyor.
3. Feed the belt assembly through the casing, past the tailshaft, and up the incline until it comes up to the headshaft sprockets. Insure cleats are facing correct direction. Refer to Figure 3, page 7.
4. Pull the top run of the belt assembly over the headshaft until the end is centered in the take-up slots.
5. Pull the bottom run of the belt assembly to remove any slack.
6. Re-install the master links and belt splice plate.
7. Be sure that all belt assembly parts are in their proper position.
8. Reinstall drive roller chain and adjust tension at the headshaft using the take-up bolts and jam nuts described under “Belt Tension Adjustment.”
9. Secure the pillow block mounting carriage bolts.
10. Operate the conveyor for approximately 15 minutes to observe and confirm trouble-free operation before placing the unit in service.

LUBRICATION

Grease Lubrication

There are a total of 4 grease fittings that require lubrication. They are located on either end of the headshaft and tailshaft. (Figure 7) Grease all bearings as follows.

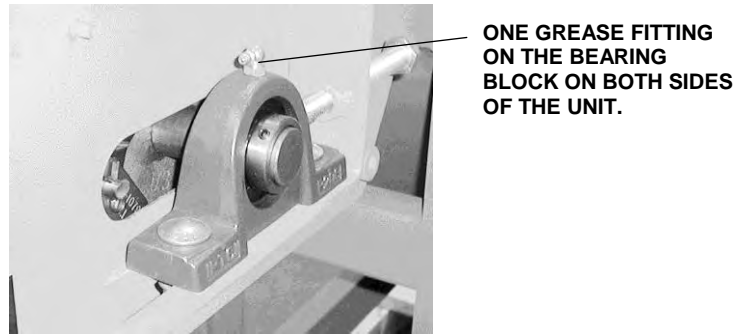

Figure 7 - Grease Fitting Location

For normal operating conditions, apply No. 2 grease through the grease fittings every 90 days. Grease should conform to NLGI No. 2 consistency, and should be free of chemical impurities such as free acid or alkali, and mechanical impurities such as dust, rust, metal particles, or abrasives. Add grease slowly until a slight bead forms between the seals.

Oil Lubrication

- The roller chain should be brushed with lightweight oil at regular intervals.
- The speed reducer on the direct drive unit is factory lubricated and sealed. It therefore requires not further lubrication.
- The indirect drive speed reducer may require periodic oil changes. Check instructions on the reducer

TROUBLESHOOTING

PROBLEM	PROBABLE CAUSE	REMEDY
Unit does not operate.	Blown fuse.	Replace fuse. Determine cause and correct.
	Tripped overload relay(s).	Determine cause and correct. Reset the relay.
	Main disconnect off.	Turn main disconnect on.
	No power to the line side of the disconnect.	Determine reason for no power and correct.
Excessive wear on chain or casing.	Conveyor not level or plumb.	Level and plumb conveyor.
	Chain or belt assembly misaligned or incorrect tension.	Align chain and/or correct tension. See Maintenance section of this manual.
	Damaged or missing chain or belt assembly parts.	Repair or replace chain.
Clutch ratcheting or slipping.	Chain/belt misaligned or incorrect tension.	Align chain and/or correct tension. See Maintenance section of this manual
	Excessive or accumulated loading.	Avoid load buildup by running conveyor continuously. Do not manually surge material into the conveyor.
	Carry-back of material into conveyor.	Collection receptacle full. Replace/empty receptacle as required.
	Incorrect clutch tension.	Refer to clutch section of this manual.
	Damaged chain or belt.	Repair or replace chain/belt.
	Accumulation of conveyed material or foreign objects inside casing.	Clean out conveyor. See Note below:
Excessive wear on chain/belt or casing.	Conveyor not level or plumb.	Level and plum conveyor.
	Chain/belt misaligned or incorrect tension.	Align chain and/or correct tension. See Maintenance section of this manual
	Carry-back of material into conveyor.	Collection receptacle full. Replace/empty receptacle as required.
	Damaged chain or belt.	Repair or replace chain/belt.
	Accumulation of conveyed material or foreign objects inside casing.	Clean out conveyor. See Note below:

Chain/belt pulses or surges.	Chain/belt misaligned or incorrect tension.	Align chain and/or correct tension. See Maintenance section of this manual
	Carry-back of material into conveyor.	Collection receptacle full. Replace/empty receptacle as required.
	Damaged chain or belt.	Repair or replace chain/belt.
	Accumulation of conveyed material or foreign objects inside casing.	Clean out conveyor. See Note below:

WARRANTY

Jorgensen Conveyors, Inc. guarantees the material of our manufacture against defects in material or workmanship under normal and proper use for a period of 24 months upon shipment. Material which we purchase can be guaranteed by use only to the extent of the original manufacturer's guarantee. We shall not be held liable for damages or delay caused by defective material, or contingent claims of any kind arising from loss of production owing to failure of shipment. Our obligation under this warranty is limited to furnishing new or replacing defective material without charge F.O.B. factory. No allowance will be made for repairs or alterations unless made with our written consent.

Caution should be used in the care and application of our products as the guarantee recited above does not apply where lack of proper maintenance or misapplication exists. We will not be liable for improper storage or handling of our products prior to placement in service.

The within equipment will be specifically designed and manufactured for and will be sold to purchaser for the sole purpose of transporting and conveying raw materials, work in process and finished goods of purchaser. Purchaser does hereby agree to exonerate, indemnify, defend and hold seller harmless of and from all loss, liability and damages which may be suffered by or asserted against the seller, and all costs and expenses which seller may incur because of any claim or claims which may be asserted against seller by any person for death or injury to anyone sustained while riding or attempting to ride upon said equipment.

JORGENSEN CONVEYORS, INC. • 10303 N. Baehr Road • Mequon, Wisconsin 53092-0156
P.O. Box 09156

Phone: 262 242 3089

Fax: 262 242 4382

www.jorgensenconveyors.com



Bulletin No. 11-01Rev., 0816