

EcoFilter[®] Conveyor Manual



Jorgensen
CONVEYORS, INC.

<p>Partial member of...</p>  <p>THE AMT MANUFACTURING TECHNOLOGY SYSTEM</p> <p>783-893-2900 • www.AMTonline.org</p>			<p>Bulletin No. 14-02, Rev. 0117</p>
--	---	---	--------------------------------------

Table of Contents

- Table of Contents 1
- DESCRIPTION..... 2
 - General..... 2
 - Conveyor Casing Construction..... 2
 - Drive and Take-Up 2
 - Conveyor Tail End..... 3
 - Conveyor Medium 4
 - Overload Devices..... 4
- INSTALLATION 5
- START UP INSTRUCTIONS..... 6
- SERVICE AND MAINTENANCE 7
 - Speed Reducer and Motor..... 7
 - Drive Adjustments 8
 - Current Limiter 9
 - Ratcheting Slip Clutch (if provided – indirect drive only) 10
 - Inspection and Adjustment of the Headshaft..... 11
 - Headshaft Shear Pin Replacement (if provided – indirect drive only) 15
 - Belt Tension Adjustment 16
 - Replacing the Headshaft 17
 - Belt Removal and Installation..... 20
 - Cleaning the Filtration Cells 22
 - Replacing the Brush Assemblies 26
 - Other Service Schedule Recommendations 28
- LUBRICATION 28
 - Grease Lubrication..... 28
 - Oil Lubrication..... 29
- TROUBLESHOOTING..... 29
- WARRANTY 32
- NOTES..... 33

DESCRIPTION

General

This manual encompasses the EcoFilter conveyor, which is a variant of the Jorgensen Conveyors metal belt conveyor.

The metal belt conveyor can be used to transport virtually all types of chips or cuttings and small-size particles, or any bulk materials. Material is carried on top of the conveyor belt. The basic application of this type of conveyor is as an elevating conveyor integrated directly into a machine tool, and/or in a conveyor system along with other types of conveyors as an elevating conveyor, with chips deposited either into a collecting container or a disposal device.

The EcoFilter conveyor utilizes filtration cells located between the upper and lower runs of belt to separate solid material from any coolant that flows thru or around the belt.

Conveyor Casing Construction

The conveyor casing is a welded, watertight unit fabricated from sheet metal sections. Tracks are welded onto the inside of the casing sidewalls. The tracks act as supports and guides for the conveyor belt.

Drive and Take-Up

The metal belt conveyor is driven by an electric motor through a speed reducer. With one option, the output of the speed reducer is connected directly to the head shaft so that torque is transmitted via the head shaft and twin sprockets to the conveyor belt or chain. Alternative options include the headshaft driven through a chain between the speed reducer and drive sprocket.

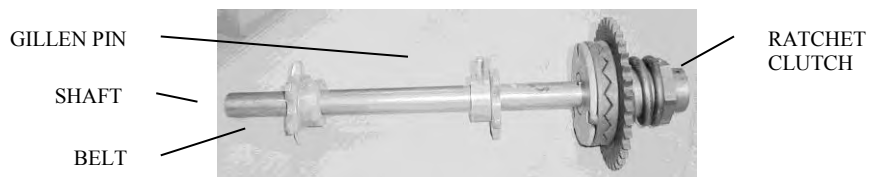

Figure 1: Headshaft



Figure 2: Direct drive

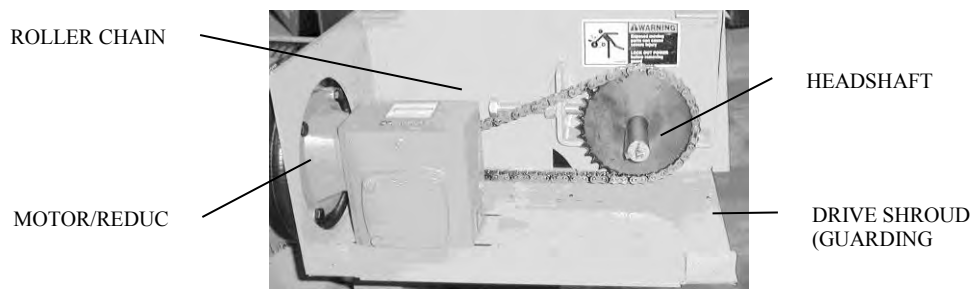

Figure 3: Indirect drive

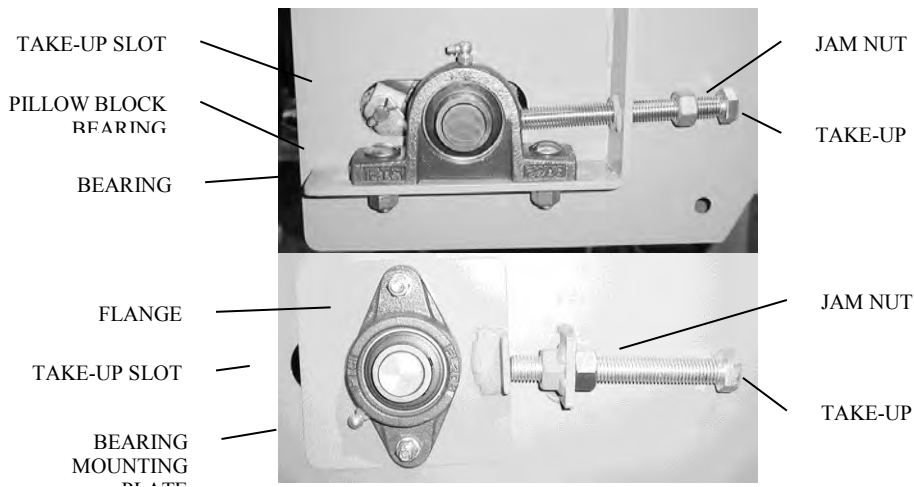

Figure 4: Belt take-up assemblies

Conveyor Tail End

The tail end of the typical metal belt conveyor consists of fixed hardened tail hubs welded to the conveyor casing. The tail hubs support and guide the chain as it makes the turn and changes direction. Larger units may use sprockets instead of hubs.

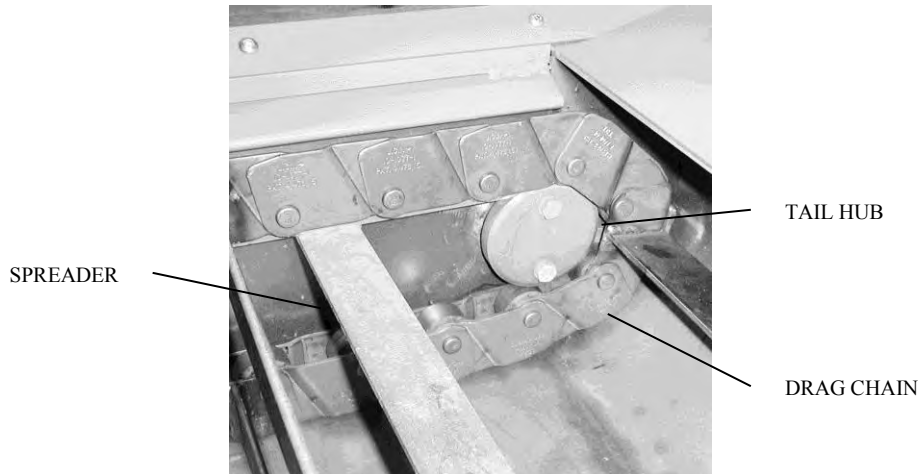

Figure 5: Tail end of drag chain conveyor.

Conveyor Medium

The metal belt conveyor consists of sheet metal chain links (apron plates), mutually linked by axles. Rollers on each end of the axles, in turn, support the axles; the rollers are supported and guided by tracks mounted on the casing. Conveyor belt pitch (the distance between axles) is either 1-1/2 or 2-1/2 inches (38 or 63 mm). The conveyor apron plates are sandwiched between side wings to contain the product being carried. The side wings are mounted on the axles, between the apron plates and the roller. Some belts are equipped with cross cleats to contain the material as it is lifted up the incline. Side bars are added to increase pulling capacity, based on the application.

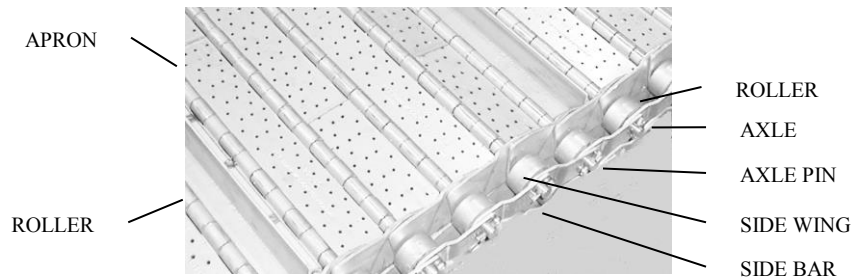

Figure 6: Metal belt

Overload Devices

These conveyors are equipped with either of three devices to prevent damage or injury due to overloading: 1) a current limiter, 2) a ratcheting slip clutch, or 3) a headshaft shear pin. Each is discussed below.

Current Limiter

The current limiter is a safety device used to protect the conveyor in the event of a jam or overload. This device is an electronic alternative to the mechanical ratchet clutch and other mechanical devices.

The current limiter senses motor current and, within milliseconds, shuts down the conveyor if the current rises above a preset level. (In some cases, contacts are also provided for an audible or visual alarm when shutdown occurs).

Depending on user preference, the current limiter option can be purchased in two different configurations:

1. Mounted in a separate electrical box along with a set of contactors.
2. Mounted in a control ordered with the conveyor and supplied by Jorgensen Conveyors.

Functionally, both configurations operate in the same manner. The current limiter is always used on the direct drive system, but it can also be used on the indirect drive system; the current limiter replaces the shear pin or ratcheting slip clutch, although the driven sprocket is still used.

Ratcheting Slip Clutch (if provided – indirect drive only)

This unit is designed to limit the torque transmitted by the drive system when the torque exceeds a preset value as a result of overload, shock load, or jamming of the conveyor. The clutch includes an adjustable compression spring that provides pressure on a pair of ratchet-tooth plates.

When a severe overload occurs, the ratchet-tooth plates, engaged on the driven sprocket, push the driven sprocket against the spring and slip on the ratchet-tooth plate until the overload is cleared. After clearing the overload, resetting is not necessary. The ratcheting slip clutch is shown in Figure 1.

Shear Pin (if provided – indirect drive only)

The headshaft may be equipped with a shear pin in the driven sprocket to prevent overload. When an overload occurs, the pin shears to remove the load from the motor and speed reducer. The shear pin must then be replaced, as explained under “Headshaft Shear Pin Replacement.”

INSTALLATION

The conveyor unit is shipped fully assembled. As a safety precaution, be sure to use the proper lifting device to unload the unit.

1. Uncrate the unit carefully, and inspect for damage that may have occurred during transit. If damage has occurred, notify the carrier immediately. Review this manual in its entirety before beginning installation. If you have any questions, call Jorgensen Conveyors immediately.
2. This unit has been lubricated, run-in, and tested in our facility. However, transportation can affect factory settings. Check for correct tensioning of the conveyor belt, and verify that all bolts in the take-up assembly and drive unit are tight. If necessary, adjust the unit as directed in this manual.
3. Check for, and remove, any loose material in the unit, especially from the base of the load section of the unit.
4. A final assembly drawing, specific to your conveyor unit, has been provided. Refer to this drawing and use the following discussion as a guide on how to proceed with installation.
5. Move the unit into position.
6. Place blocking and shimming under the full width of the load section of the unit to distribute weight uniformly. Be sure that the unit is level side-to-side (end-to-end is not important) and that the unit interfaces correctly with the machine.

Note: Some units are equipped with adjustable casters to allow movement of the unit. Others are equipped with adjustable articulated leveling bolts.
7. Connect all piping and couplings, and verify that all fittings are tight.
8. Refer to the electrical schematic (shipped with the unit) and connect electric power according to the schematic.

START UP INSTRUCTIONS

Initially (and after prolonged shutdown) be sure that the conveyor drive has been correctly wired and that all covers and shrouds are in place.

Operate the conveyor for approximately 15 minutes to observe and confirm trouble-free operation before placing the unit in service. (The unit is usually operated through pushbuttons located on the machine, although, when requested, the controls can be mounted on the conveyor.)

If the conveyor has been shut down for a prolonged period, proceed as follows:

1. Check for correct tensioning of the conveyor belt, as describe later under “Belt Tension Adjustment.”
2. Verify that all bolts in the take-up assembly and drive unit are tight.
3. Be sure that the roller chain on the indirect drive unit has been properly lubricated (brushed with light-weight oil).
4. If an unsealed indirect drive speed reducer is used, be sure that the speed reducer is correctly lubricated, as described later in this manual under LUBRICATION.”

NOTE – NO INTERMITTENT RUNNING!

Jorgensen Conveyors, Inc. has designed each Ecofilter conveyor’s features specifically for its unique application. These features include the Ecofilter’s internal cell cleaning system. The brush layout, quantity, and spacing is directly related to the speed of the belt and size of the cell in order to maintain a constant cleaning process of the Ecofilter cell. This means the conveyor belt must run constantly while the machine is in operation. Running the belt on any intermittent on/off cycle will result in an improper cleaning cycle of the cell and, thus, will result in a decrease in filtration performance. Jorgensen Conveyors, Inc. cannot guarantee the performance of the Ecofilter conveyor on any intermittent on/off cycle.

SERVICE AND MAINTENANCE

The conveyor requires regular maintenance, including lubrication, in order to sustain trouble-free operation.

Speed Reducer and Motor

Direct Drive Units

The speed reducer is a two-stage system. The speed reducer is lubricated and sealed by the manufacturer and does not require further lubrication. The motor bearings are also sealed and do not require further lubrication.

Indirect Drive Units

Optionally, conveyors may be equipped with a roller chain in conjunction with a speed reducer. These may require periodic lubrication, and the roller chain may require occasional adjustment.

Indirect Drive Reducer Lubrication

The speed reducer used in the indirect drive system may require periodic lubrication. Recommended lubrication oil is shown later under “LUBRICATION” in Table 2. For unusual temperatures, or to use synthetic oils, contact the manufacturer.

Drive Adjustments

Drive V-Belt Adjustment

1. Check the sheave alignment between the motor and speed reducer by placing a straight edge across the face of the sheave faces (Figure 7). Inside and outside sheave diameters should be touching the straight edge at all four points as shown in the illustration. Alignment of the sheaves should be within ± 0.5 degrees or 1/8" per foot (3 mm per 0.3 m).
2. Check for belt wear or fraying. Check for whip action (side to side) or tension problems.
3. Check tension as follows:
 - Measure the span length as shown in Figure 7.
 - Check belts and components. Be sure that all are in good condition and free from contamination. The belt should be free from chips or turnings.
 - Check belt tension by pressing firmly on the individual belt. A belt that can be depressed an amount equal to 1/64th inch per inch of span (0.4 mm per 25 mm of span) is properly tensioned (Figure 7).
 - The ideal tension is the lowest tension at which the belt does not slip under peak load conditions. Over-tightening the belt will shorten belt and bearing life.
 - If the setscrews have been loosened, be sure that they are re-tightened.

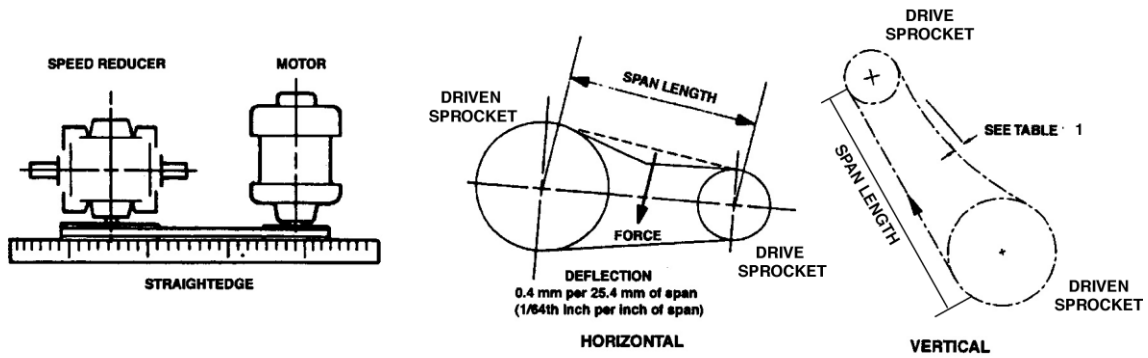

Figure 7: Reducer/Motor Alignment and Tension Adjustment

Roller Chain Adjustment

1. Check sprocket alignment using a straight edge or taut cord stretched across the faces of the drive sprocket and the driven sprocket (Figure 7). The tolerance is ± 0.5 degrees or $1/8$ " per foot (3.5 mm per 0.3 m).
2. Check sprockets and components. Be sure that all are in good condition and free from contamination. The roller chain should be lubricated and free from chips or turnings.
3. Check roller chain tension. Deflection of the span is shown in Figure 7 and Table 1.
4. Be sure all setscrews, bolts, and nuts are tight.
5. Lubricate the roller chain by brushing with lightweight oil.

Table 1: Deflection of Roller Chain Between Sprockets

DRIVE CENTER	12.7 cm 5"	25.4 cm 10"	38.1 cm 15"	50.8 cm 20"	76.2 cm 30"	101.6 cm 40"	152.4 cm 60"	203.2 cm 80"	254 cm 100"
Horizontal	.64 cm .25"	1.27 cm .50"	1.91 cm .75"	2.54 cm 1.00"	3.81 cm 1.50"	5.08 cm 2.00"	7.62 cm 3.00"	10.16 cm 4.00"	12.7 cm 5.00"
Vertical	.31 cm .12"	.64 cm .25"	.97 cm .38"	1.27 cm .50"	1.91 cm .75"	2.54 cm 1.00"	3.81 cm 1.50"	5.08 cm 2.00"	6.35 cm 2.50"

Current Limiter

WARNING: When the current limiter stops the conveyor, there may be residual torque on the drive system. It is essential that the conveyor be operated in reverse momentarily to relieve the residual torque. Never attempt to clear a jam or work on the conveyor without first relieving the torque.

The current limiter can best be adjusted with the conveyor operating under typical load:

1. With the conveyor running, gradually turn the adjustment knob on the limiter counter-clockwise until the limiter trips out and stops the conveyor.
2. After the conveyor has stopped, adjust the setting a small amount higher and restart the conveyor. If the conveyor runs without being shut down by the current limiter, you are ready to begin normal operation.
3. If the limiter still trips, repeat the above procedure until the conveyor runs continuously without tripping out. This setting will be a good starting point; through experience with the specific chips and load procedures, you may want to adjust the limiter accordingly.

Ratcheting Slip Clutch (if provided – indirect drive only)

This unit is preset at Jorgensen Conveyors, and should only require resetting if clearing the overload does not stop the ratcheting. Refer to Figure 8 and proceed as follows:

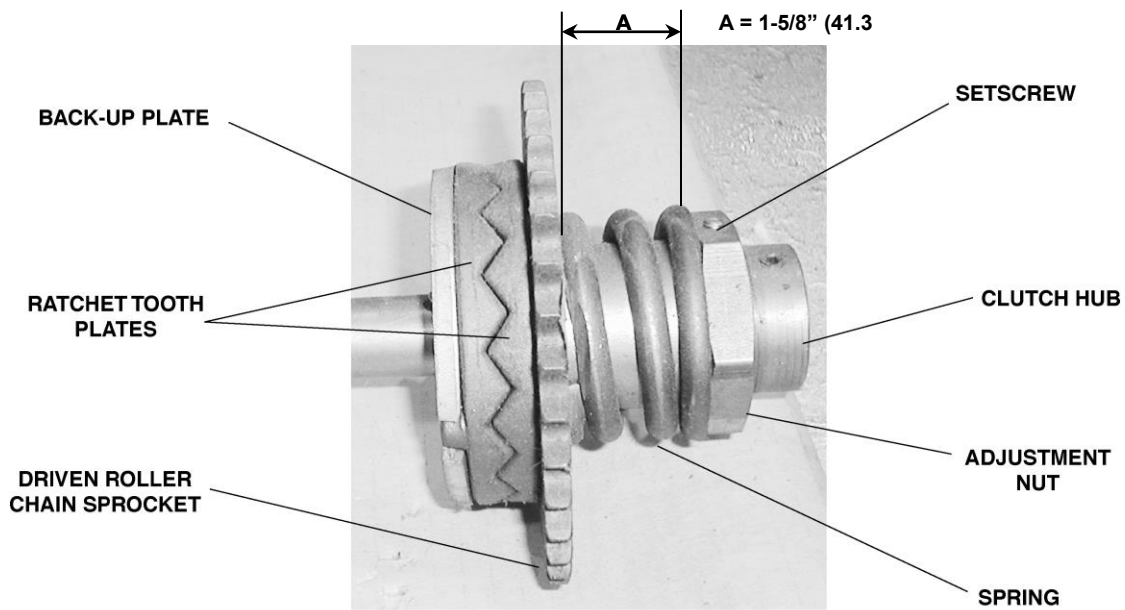

Figure 8: Ratchet Slip Clutch

1. Clear the conveyor of any jamming material or overload.
2. Load the conveyor with the maximum expected load.

WARNING: When the clutch stops the conveyor, there may be residual torque on the drive system. It is essential that the conveyor be operated in reverse momentarily to relieve the residual torque. Never attempt to clear a jam or work on the conveyor without first relieving the torque.

WARNING Failure to follow safety procedures can cause personal injury! Disconnect all electrical power from the conveyor unit before servicing the ratchet slip clutch.

3. Lock out and tag out electrical power to the conveyor unit.
4. Remove all drive guards and/or covers.
5. Loosen the setscrew on the clutch-adjusting nut. Tighten the adjusting nut 1/4 turn.

Note: The ratchet slip clutch is preset at Jorgensen Conveyors to 1-5/8” (41.3 mm) (A, Figure 8). Do not compress the spring to anything less than 1-1/2” (38.1 mm) because this would disable the clutch.

6. Apply electric power, restart the conveyor, and observe operation of the clutch. If the overload (ratcheting) continues, lock out and tag out electric power to the conveyor and continue with Step 7.
7. Repeat steps 5 and 6 until the conveyor runs continuously without ratcheting.
8. After final adjustment, lock the adjusting nut in place with the setscrew.
9. If the conveyor is now functioning properly, replace the guards and covers, and return the unit to service.
10. The only maintenance required for the ratchet slip clutch is periodic inspection for wear, rust, corrosion, or binding between the ratchet-tooth plates.

Inspection and Adjustment of the Headshaft

WARNING: Failure to follow safety procedures can cause personal injury. Disconnect all electrical power from the conveyor unit before removing the headshaft cover or servicing the headshaft assembly.

1. Lock out and tag out electrical power to the conveyor unit.
2. Remove any drive system covers.
3. Move the drive motor/speed reducer assembly on its adjustment screws to relieve tension on the roller chain.
4. Disconnect the master link from the roller chain and remove the chain from the headshaft drive sprocket. Remove covers, as necessary, to expose the headshaft.

5. The headshaft can be now be inspected as follows:
 - A. If the metal belt runs against the sides of the conveyor or wanders from side to side:
 - a. Measure the distance between the headshaft sprocket face (or chain face) and the inside of the sidewall on both ends of the shaft to verify that the drag chain or metal belt is centered in the discharge section (Figure 9). If not, proceed as follows:

MEASURE DISTANCE BETWEEN CHAIN FACE OR SPROCKET FACE AND SIDE PLATE ON BOTH SIDES TO DETERMINE CENTERING HEADSHAFT

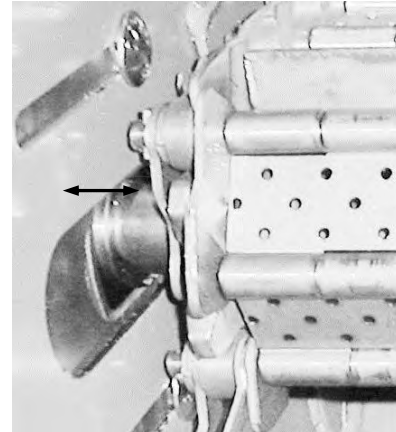

Figure 9: Headshaft Centering Measurement

- Loosen the setscrews on the flange bearing or pillow block bearing so that the headshaft can be moved laterally.

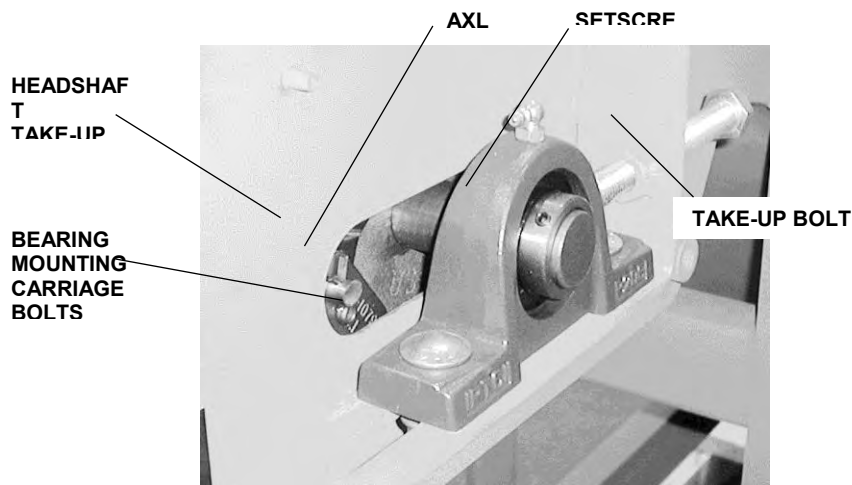

Figure 10: Headshaft Take-Up Slot

- Move the shaft and sprocket towards the side of the machine having the greatest clearance.
 - Measure the distance between the chain face (or sprocket face) and the inside of the sidewall (Figure 9). Be sure that the sprockets are centered (distance is equal for both sides).
 - Retighten the bearing block setscrews.
- b. If the metal belt still runs against the side of the conveyor, or if the chain or belt “climbs” the sprockets:

- Measure the distance between the bearing and the front edge of the sidewall (Figure 11) to verify that the headshaft is not cocked.

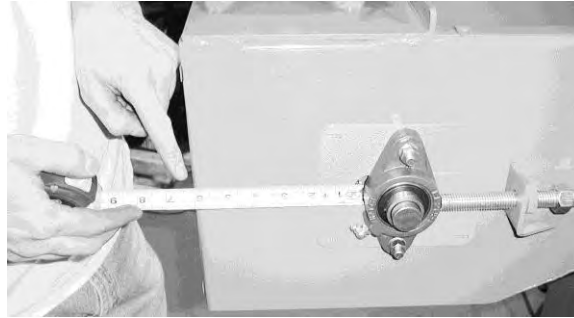

Figure 11: Checking for Headshaft Skew

- If the shaft is skewed, loosen the bearing block mounting carriage bolts on the lagging side and, using the take-up device, balance the position of the headshaft in the discharge section.
 - Tighten the bearing block bolts.
- c. If the metal belt climbs the sprockets even after steps (a) and (b) have been completed, belt tension may be too loose. Check belt tension as described under “Belt Tension Adjustment” below.
- B. If the driven sprocket turns but the headshaft does not, check the drive key to ensure that it is not sheared (Figure 13). If the key is not sheared, see “Replacement of Headshaft Shear Pin.”
- C. If the headshaft turns, but the chain does not move, inspect the headshaft gillen pins or keys (Figure 12) (In some cases, a sprocket key is used instead of a pin). If the pins or keys are damaged, refer to “Removal of Headshaft Assembly” below.

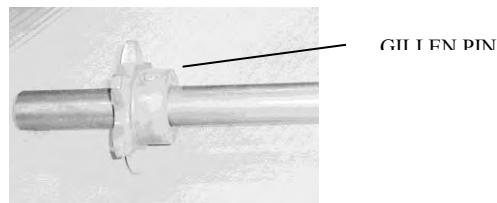

Figure 12: Gillen Pin

- D. If the headshaft has lateral movement in the bearings: Check the headshaft-bearing mounting carriage bolts for tightness (Figure 10). If either is loose, proceed as follows:

- Adjust the headshaft so that the chain is equidistant between the chain and the inside of the side plate on each side (Figure 9).
- Tighten the headshaft-bearing mounting carriage bolts.

E Headshaft is seized and does not rotate: refer to “Removal of Headshaft” below.

6. Reinstall the roller chain, and adjust tension (indirect drive).
7. Reinstall all covers and shrouds.
8. Apply electrical power.

Headshaft Shear Pin Replacement (if provided – indirect drive only)

WARNING: Failure to follow safety procedures can cause personal injury. Disconnect all electrical power from the conveyor unit before removing the headshaft cover or servicing the headshaft assembly.

1. Lock out and tag out electrical power to the conveyor unit.

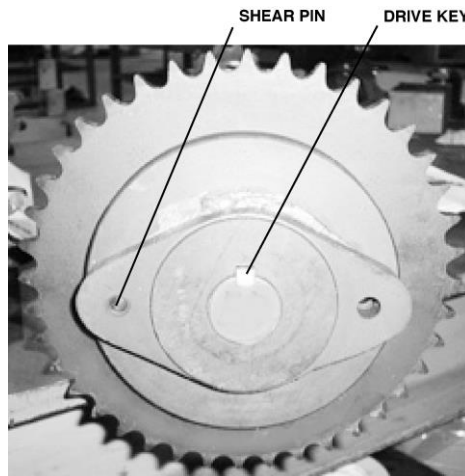

Figure 13: Driven Sprocket Shear Pin and Drive Key

2. Remove all covers and shrouds covering the drive system.
3. Move the drive motor forward on its adjustment screws to relieve tension on the roller chain.
4. Disconnect the master link from the roller chain and remove the roller chain from the headshaft drive sprocket.

5. Loosen the bearing mounting carriage bolts.
6. From the discharge section, push the headshaft to relieve tension on the metal belt.
7. Remove any pieces of the broken shear pin from the driving and driven members of the hub.
8. Align the driving and driven members of the hub, and insert the replacement shear pin.
9. Verify that the replacement shear pin is correctly aligned in the hub.
10. Using the take-up device, apply tension to the conveyor metal belt. See “Belt Tension Adjustment” below.
11. Tighten the bearing mounting carriage bolts to prevent headshaft movement.
12. Reinstall the drive safety covers and guards over the drive system.
13. Reinstall the roller chain and adjust the drive motor chain tension as described under “Drive Chain Adjustment.”
14. Apply electrical power to the unit.

Belt Tension Adjustment

Conveyor chains eventually stretch with operation so that tension must occasionally be adjusted using the take-up mechanism as follows:

1. Lock out and tag out the conveyor.
2. Remove covers and guards.
3. Loosen the jam nuts and take-up bolts.

Note: On indirect drive units, remove the roller chain between the speed reducer and headshaft sprocket to free the headshaft for movement using the take-up device. Remove the master link on the roller chain to remove the chain.

4. Adjust the take-up bolts to shift the headshaft in the required direction to increase or decrease tension. Be sure that both sides are tensioned uniformly so that the headshaft is not askew, which would increase wear on the chains and sprockets.

Warning: Never check belt or chain tension using your hand while the conveyor is operating. Failure to observe this warning can result in severe injury to your hand.

5. Check belt tension with your hand as shown in Figure 14. Belt slack at this position should be approximately 1/2 to 3/4 inch (13 to 19 mm).



Figure 14: Checking Metal Belt Tension

6. Tighten the take-up retaining bolts and jam nuts.
7. Remove the tagout and restart the conveyor. Allow the conveyor to operate for 15 minutes and observe that the belt does not drift sideways, which would indicate skewing.
8. Install and secure all covers and guards.

Replacing the Headshaft

Removal of the Headshaft Assembly

1. Carefully jog the conveyor until an axle is accessible through the take-up slots.

WARNING: Failure to follow safety procedures can cause personal injury. Disconnect all electrical power from the conveyor unit before removing the headshaft cover or servicing the headshaft assembly.

2. Lock out and tag out electrical power to the conveyor unit.
3. Remove all necessary covers and shrouds.
4. On the direct drive system remove the drive motor/speed reducer assembly.

Note: On indirect drive units, remove the roller chain between the speed reducer and driven sprocket to free the headshaft for movement. Remove the master link on the roller chain to remove the chain.

5. Loosen the jam nuts and take-up bolts, and loosen the bearing mounting carriage bolts.

Note: If the unit is equipped with a ratchet slip clutch, loosen the setscrew on the clutch hub and remove the slip clutch.

6. At the discharge section, push the headshaft to relieve tension on the metal belt.
7. Remove an axle pin from the drive side of the axle aligned with the take-up slot. Because the axle pins are press fit, it will be necessary to use a hammer and drive pin to remove the axle pin.



Figure 15: Removing the Axle Pin

8. Remove the axle from the non-drive side as shown in Figure 16. Install the axle and roller back into the top half of the metal belt to avoid losing the axle, pin, side wings and roller.

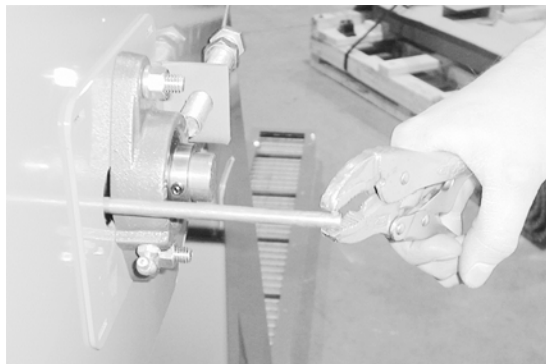

Figure 16: Removing the Axle on a Metal Belt Conveyor

9. Facing the discharge opening, pull on the lower half of the metal belt until the upper run clears the headshaft; lower the lower run onto the upper curve (Figure 17).
10. Loosen the setscrews securing the bearings to the headshaft.
11. Remove the *non-drive* side bearing from the headshaft.
12. Remove the driven sprocket from the drive side of the conveyor by removing the setscrew in the sprocket hub.
13. Via the discharge opening, drive out the sprocket pin on the drive end of the headshaft (Figure 17), or loosen set screws in hub if keys are used. With the sprocket now free to move, slide the sprocket toward the non-drive side of the headshaft.

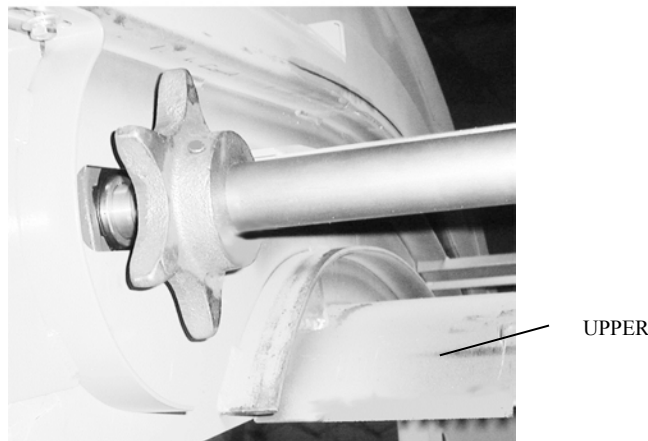

Figure 17: Interior of Conveyor Discharge

14. Push the headshaft towards the drive side, moving it out of the non-drive side bearing plate. Then lower the non-drive end of the headshaft and remove the entire headshaft to a safe working area.

Installation of the Headshaft Assembly

Installation of the headshaft assembly is basically the reverse of the removal process. Upon completion of installation, refer to “Belt Tension Adjustment” below to complete installation.

1. Slide the headshaft into the drive side of the conveyor and then into the non-drive side.
2. Drive the press fit gillen pin into the hole in the headshaft, or install the sprocket key if the unit is so equipped.

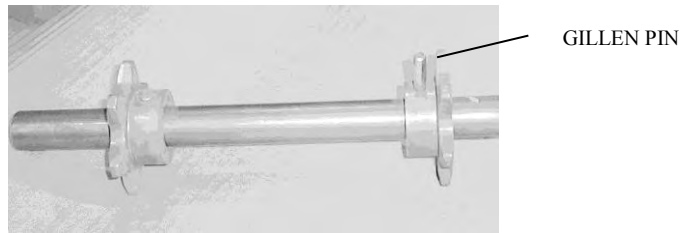

Figure 18: Installing the Headshaft

3. Install the bearings and bearing blocks/flanges and the sprocket/ratcheting slip clutch on the headshaft. Install the clutch-hub-mounting setscrew, but do not tighten the bearing block mounting carriage bolts at this time.
4. Refer to “Inspection and Adjustment of the Headshaft,” above, and center the sprocket/headshaft assembly in the conveyor.
5. After the sprocket has been aligned, tighten the bearing block and/or flange mounting carriage bolts.
6. Reinstall the metal belt over the headshaft and secure it with the appropriate items.
7. Operate the conveyor for approximately 15 minutes to verify correct alignment.

Belt Removal and Installation

The procedure to remove and install the metal belt assemblies is virtually identical. Hence, they are discussed at the same time below.

Removal

Proceed as follows:

1. Carefully jog the conveyor until an axle is accessible through the take-up slots.

WARNING: Failure to follow safety procedures can cause personal injury. Disconnect all electrical power from the conveyor unit before removing the headshaft cover or servicing the headshaft assembly.

2. Lock out and tag out electrical power to the conveyor unit.
3. Remove all necessary covers and shrouds.
4. On the direct drive unit, remove the drive motor/speed reducer assembly.

Note: On indirect drive units, remove the roller chain between the speed reducer and headshaft sprocket to free the headshaft for movement. Remove the master link on the roller chain to remove the chain.

5. Loosen the jam nuts and take-up bolts.
6. Loosen the bearing mounting carriage bolts.
7. At the discharge section, push the headshaft to relieve tension on the metal belt.

Note: In the following instructions, the metal belt will be removed and lowered to the floor. This may require two persons or even an overhead lift.

8. Remove an axle pin from the drive side of any axle (Figure 15). Because the axle pins are press fit, it may be necessary to use a hammer and drive pin to remove the axle pin.
9. Remove the axle from the non-drive side as shown in Figure 16. Install the axle and pins, and rollers back into the top half of the metal belt to avoid losing the parts.
10. Facing the discharge opening, pull on the lower half of the metal belt and remove the entire metal belt out of the discharge section. Lower the belt to the floor and allow it to fold beneath the discharge section.
11. Remove all foreign objects from the casing.
12. Inspect the metal belt assembly and casing for worn or damaged parts and repair/replace as required.

Installation

Installing the metal belt assembly is essentially the reverse procedure discussed under “Removal.” Proceed as follows:

1. Be sure that the headshaft is pushed all the way back.
2. Feed the end of the metal belt assembly into the lower run of the conveyor casing through the discharge section. Be sure that the wings face downward; i.e. toward the bottom of the conveyor.
3. Feed (push) the metal belt assembly through the casing, past the tail hub, and up the incline until it comes up to the headshaft sprockets.

4. Pull the top run of the metal belt assembly over the headshaft until the end is centered in the take-up slots.
5. Pull the bottom run of the metal belt assembly to remove any slack.
6. Re-install the chain pins, rollers, and axles through the take-up slots:
 - Install the axle through the non-drive take-up slot and roller.
 - If the axle pins have been removed from both ends of the axle, press the axle pin into the hole on one end of the axle.
 - Push the axle all the way through the belt and through the roller on the drive side of the belt.
 - Install the drive side pin using a hammer and rod as shown in Figure 15.
7. Be sure that all metal belt assembly parts are in their proper position.
8. Reinstall the drive motor/reducer assembly, or roller chain (indirect drive), and adjust tension at the headshaft using the take-up bolts and jam nuts as described under “Belt Tension Adjustment.”
9. Secure the pillow block mounting carriage bolts.
10. Operate the conveyor for approximately 15 minutes to observe and confirm trouble-free operation before placing the unit in service.

Cleaning the Filtration Cells

WARNING: Failure to follow safety procedures can cause personal injury. Disconnect all electrical power from the conveyor unit before servicing the filtration cells.

WARNING: When handling filtration cells, PPE (Personal Protective Equipment) is recommended due to exposure of metal chips, which could lead to injury if handled without protection.

It is recommended that the filtration cells are removed from the conveyor annually to be cleaned and inspected for wear or damage. After the conveyor has been removed from the coolant tank and all coolant has been drained from the conveyor, perform the following steps:

Removal

1. Remove all of the fasteners holding the filtration cell in the conveyor.

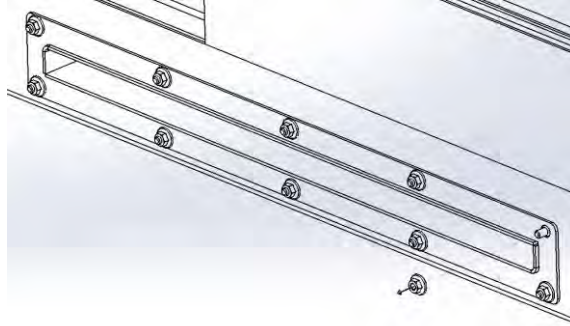

Figure 19: Remove fasteners

2. Pull on the filtration cell evenly until the entire unit has been removed from the conveyor.

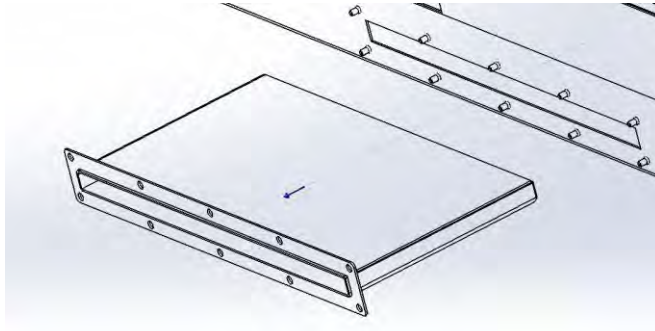

Figure 20: Remove filter

Cleaning

Method 1:

1. Clean off the outside of the filter.
 - a. In most cases, scrubbing the filter with a rag or brush will be enough to dislodge the material from the surface of the screen.



Figure 21: Scrub Screen

- b. A putty knife, steel brush, or other scraper may be needed to remove more aggressively stuck particles. The edge of the scraper should be held perpendicular to the direction of the slot openings, and the scraping motion should be parallel to the direction of the slot openings. Cleaning in a contradictory manner to this instruction may result in damage to the filtration screen.



Figure 22: Scrape Filter

2. Dislodge material from between the wires using a compressed air nozzle.



Figure 23: Blow-off Filter

3. Remove any remaining debris from inside the filter.

Method 2:

1. Wash the filter outside and inside with a pressure washer.

Installation

1. Evenly push the filter back into the opening in the side of the conveyor until the flange is flush against the conveyor casing (Figure 24A). Gaps between the flange and conveyor indicate that the filter is not properly seated (Figure 24B). An improperly fastened filter cell may interfere with the conveyor belt and cause jamming.

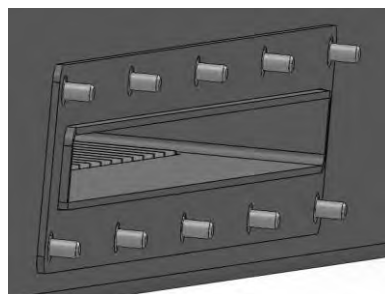

Figure 24A: Correct

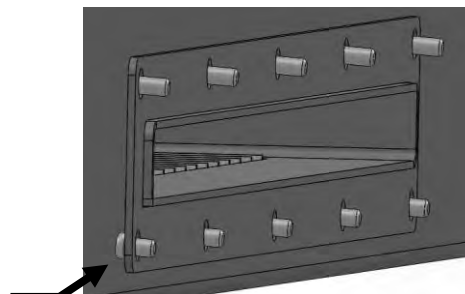

Figure 23B: Incorrect

2. Replace all lock-nuts, starting with the center-bottom stud.

Cleaning the Clean Cleat®

WARNING: Failure to follow safety procedures can cause personal injury. Disconnect all electrical power from the conveyor unit before servicing the conveyor belt.

If the Clean Cleat® assemblies become clogged with solids, they may be flushed out with a compressed air nozzle.

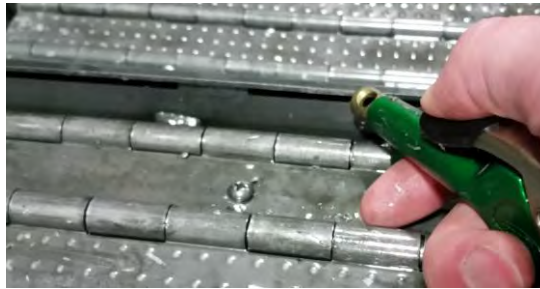

Figure 25: Spray Thru Openings

Replacing the Brush Assemblies

WARNING: Failure to follow safety procedures can cause personal injury. Disconnect all electrical power from the conveyor unit before servicing the conveyor belt.

It is recommended that the brush assemblies are inspected for wear or damage whenever the belt is removed from the conveyor. If the brushes are damaged, they may be replaced by the following procedure (skip steps 1, 2, and 4 if the belt has already been removed from the conveyor):

1. Remove a filter cell or cover plate to create an inspection window.

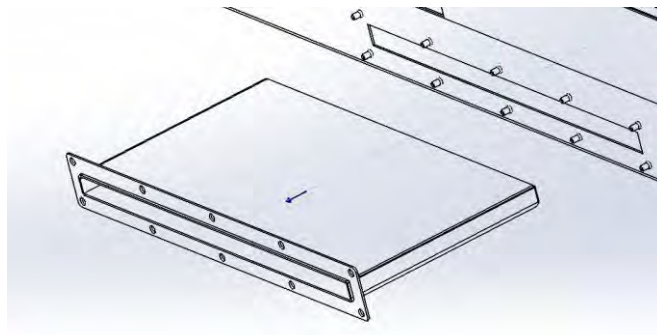

Figure 26: Remove Filter

2. Jog the conveyor until a brush is visible in the inspection window.

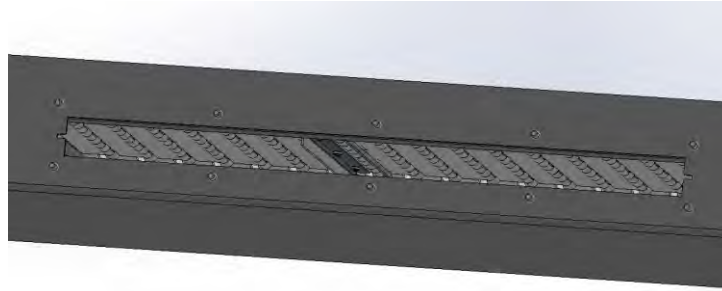

Figure 27: Brush in Inspection Window

3. Unfasten the screws holding the aluminum brush holders on the belt.

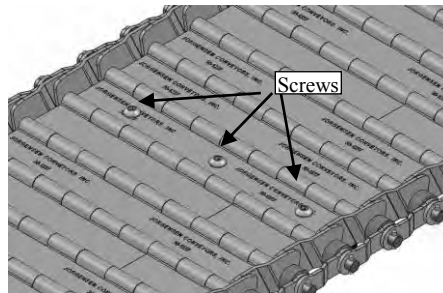

Figure 28: Topside of Belt

4. Remove the brush holder through the inspection window.
5. Slide the brush out of the side of the brush holder and discard the damaged brush.



Figure 29: Remove and/or Insert From the Side of the Holder

6. Insert a new strip brush into the side of the aluminum brush holder.

7. Fasten the brush holder back onto the conveyor belt.
8. Repeat step 2-7 as needed to replace any other damaged brushes.
9. Replace all covers, filters and guards.

Other Service Schedule Recommendations

- Check the metal belt components every six months for indications of wear or damage.
- Check the general condition of the casing and verify that all casing bolts are tight every six months.
- It is recommended that the conveyor belt is removed annually to clean the casing and to check the following components for wear and damage:
 - a. Conveyor tracks
 - b. Headshaft sprockets
 - c. Tail hubs (or sprockets on larger units)

LUBRICATION

Grease Lubrication

There are a total of 2 grease fittings that require lubrication – one on either end of the headshaft to lubricate the head shaft bearings. Grease all bearings as follows.

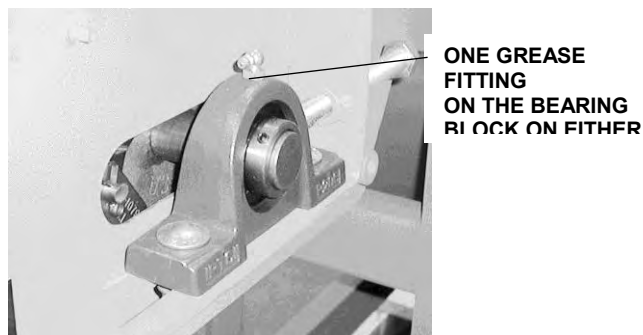

Figure 30: Grease Fitting Location

For normal operating conditions, apply No. 2 grease through the grease fittings every 90 days. Grease should conform to NLGI No. 2 consistency, and should be free of chemical impurities such as free acid or alkali, and mechanical impurities such as dust, rust, metal particles, or abrasives. Add grease slowly until a slight bead forms between the seals.

Oil Lubrication

- The roller chain should be brushed with lightweight oil at regular intervals.
- The speed reducer on the direct drive unit is factory lubricated and sealed. It therefore requires no further lubrication.
- The indirect drive speed reducer may require periodic oil changes. Check instructions on the reducer.

NOTE: When changing oil in a double-reduction unit, be sure the primary and secondary chambers are both changed.

Table 2: Suggested Speed Reducer Lubricants

AMBIENT TEMPERATURE OF OPERATING ENVIRONMENT	RECOMMENDED OIL
-30 to 225 °F	Mobil SCH 634 Synthetic Oil
40 to 90 °F	Mobil 60W Cylinder Oil
80 to 105 °F	Mobil Extra Hecla Super Cylinder Oil

TROUBLESHOOTING

PROBLEM	PROBABLE CAUSE	REMEDY
Unit does not operate.	Blown fuse.	Replace fuse. Determine cause and correct.
	Tripped overload relay(s).	Determine cause and correct. Reset the relay.
	Main disconnect off.	Turn main disconnect on.
	No power to the line side of the disconnect.	Determine reason for no power and correct.
Excessive wear on chain or casing.	Conveyor not level or plumb.	Level and plumb conveyor.
	Chain or belt assembly misaligned or incorrect tension.	Align chain and/or correct tension. See Maintenance section of this manual.
	Damaged or missing chain or belt assembly parts.	Repair or replace chain.
Clutch ratcheting or slipping.	Chain/belt misaligned or incorrect tension.	Align chain and/or correct tension. See Maintenance section of this manual

	Excessive or accumulated loading.	Avoid load buildup by running conveyor continuously. Do not manually surge material into the conveyor.
	Carry-back of material into conveyor.	Collection receptacle full. Replace/empty receptacle as required.
	Incorrect clutch tension.	Refer to clutch section of this manual.
	Damaged chain or belt.	Repair or replace chain/belt.
	Accumulation of conveyed material or foreign objects inside casing.	Clean out conveyor. See Note below:
Excessive wear on chain/belt or casing.	Conveyor not level or plumb.	Level and plum conveyor.
	Chain/belt misaligned or incorrect tension.	Align chain and/or correct tension. See Maintenance section of this manual
	Carry-back of material into conveyor.	Collection receptacle full. Replace/empty receptacle as required.
	Damaged chain or belt.	Repair or replace chain/belt.
	Accumulation of conveyed material or foreign objects inside casing.	Clean out conveyor. See Note below:
Chain/belt pulses or surges.	Chain/belt misaligned or incorrect tension.	Align chain and/or correct tension. See Maintenance section of this manual.
	Carry-back of material into conveyor.	Collection receptacle full. Replace/empty receptacle as required.
	Damaged chain or belt.	Repair or replace chain/belt.
	Accumulation of conveyed material or foreign objects inside casing.	Clean out conveyor. See Note below:
Coolant floods conveyor	Conveyor is not run often enough to allow brushes to clean the filter	Run the conveyor nonstop to allow the filter to be cleaned continuously
	Openings in filtration cells are occluded by solids	See "Cleaning the Filtration Cells."
	Brush assemblies are worn or damaged, and cannot effectively clean filters	See "Replacing the Brush Assemblies."

Note: To quickly clean out the metal belt conveyor, proceed as follows. Remove all objects or debris from the topside of the belt. Roll up or wad up newspaper and place the newspaper at the tail of the conveyor. Operate the conveyor in reverse. This will carry the paper back into the conveyor so that the paper “wipes out” the inside of the conveyor. Operate the conveyor in the reverse direction until all the paper has been discharged. Repeat this procedure until the casing is clean.

WARRANTY

Jorgensen Conveyors, Inc. guarantees the material of our manufacture against defects in material or workmanship under normal and proper use for a period of one year in service or eighteen months from shipment, whichever occurs first. Material which we purchase can be guaranteed by use only to the extent of the original manufacturer's guarantee. We shall not be held liable for damages or delay caused by defective material, or contingent claims of any kind arising from loss of production owing to failure of shipment. Our obligation under this warranty is limited to furnishing new or replacing defective material without charge F.O.B. factory. No allowance will be made for repairs or alterations unless made with our written consent.

Caution should be used in the care and application of our products as the guarantee recited above does not apply where lack of proper maintenance or misapplication exists. We will not be liable for improper storage or handling of our products prior to placement in service.

The within equipment will be specifically designed and manufactured for and will be sold to purchaser for the sole purpose of transporting and conveying raw materials, work in process and finished goods of purchaser. Purchaser does hereby agree to exonerate, indemnify, defend and hold seller harmless of and from all loss, liability and damages which may be suffered by or asserted against the seller, and all costs and expenses which seller may incur because of any claim or claims which may be asserted against seller by any person for death or injury to anyone sustained while riding or attempting to ride upon said equipment.

NOTES

UNIT SERIAL NUMBER: _____

JORGENSEN CONVEYORS, INC. • 10303 N. Baehr Road • Mequon, Wisconsin 53092-0156
P.O. Box 09156

Phone: 262-242-3089

Fax: 262-242-4382

www.jorgensenconveyors.com

Jorgensen[®]
CONVEYORS, INC.

Bulletin No. 14-02, Rev. 0117