

# OPERATOR MANUAL

## Gravity Media Filter

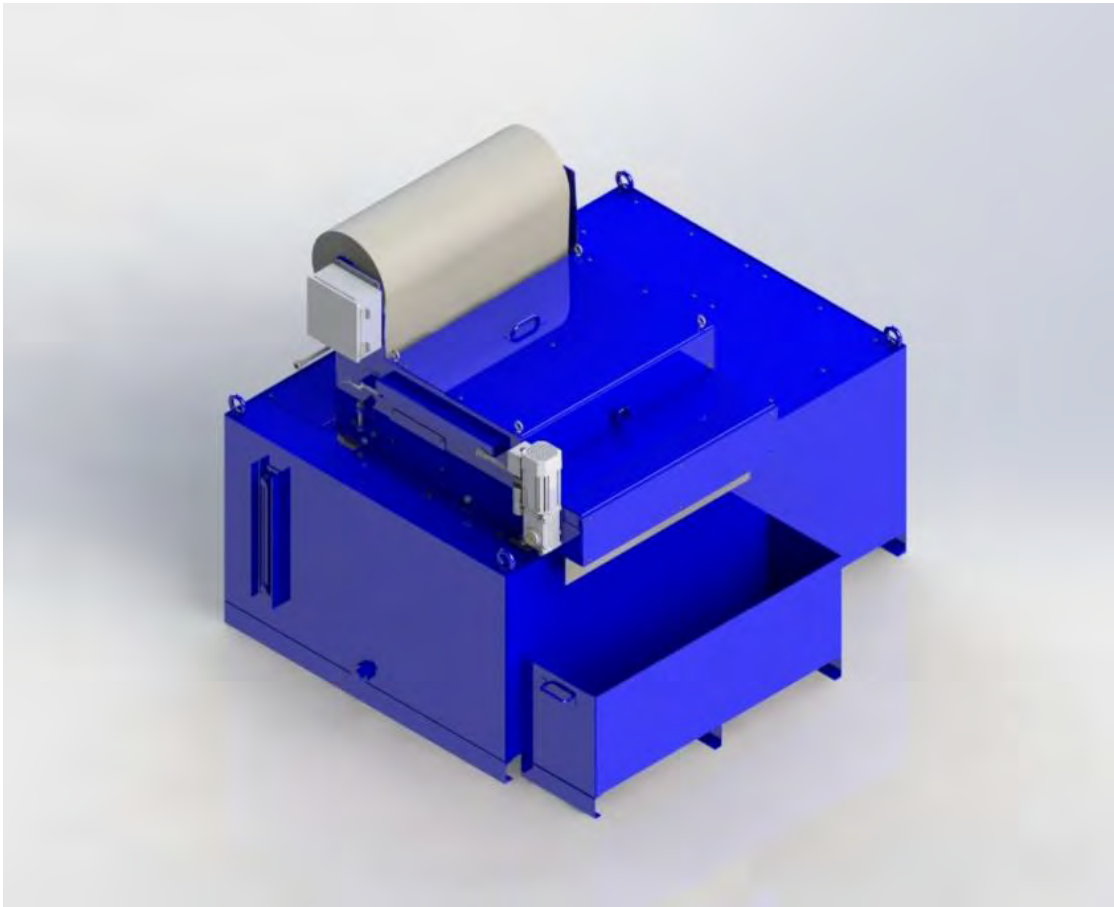

## Table of Contents

	Introduction	
	Theory of Operation	1
	Disposable Filter Media	2
Section I.	Identification of Major Components	3
	Liquid Level Sensor	4
	Drive Shaft	4
	Terminal Box and Harting Connector	5
	Index drive	5
	Filter Mounting Bolts	5
	Seal and Seal Wheel Assembly	5
	Seal Wiper	5
Section II.	Operation	6
	Threading of Media	6
	Standard Control	6
Section III.	Maintenance	8
	Drive Chain Adjustment	8
	Removal of Seal Wheel Assembly	8
	Replacing Seal Wheel Seal	8
	Replacing Drive Shaft Bearing	11
	Removal of Drive Shaft	12
	Removal of Mesh Belting	13
	Replacement of Mesh Belting	13
	Spare Parts	16

## **Introduction**

Gravity Media Filters are generally utilized in grinding applications or other applications where filtration of fine particulate is required. Jorgensen Conveyors' Gravity Media Filter and tanks are modules allowing a system to be configured to each application's requirement.

## **Theory of Operation**

Refer to Section I. Identification of Major Components for clarification.

The Jorgensen Conveyors Gravity Media Filter is available in three different sizes, 30, 60 and 90 GPM. Dirty coolant is either pumped from the machine or gravity flows to the inlet of the Gravity Media Filter, dependent on size. After entering the inlet, dirty coolant is directed to an area inside the filter between two Seal Wheels. It is allowed to puddle while it filters through the media. Particulate remains on the surface of the media, after the coolant has filtered through and drained into the tank below the filter.

As particulate builds on the media, it creates a "cake" or in the case of extremely fine particulate a "film" on the media. This cake or film enhances filtration, providing cleaner coolant to the clean tank. As the cake builds the coolant level increases between the Seal Wheels as it cannot drain at the same rate as before the cake developed. The rising coolant level eventually contacts the liquid level sensor.

The level sensor will initiate a paper index. A paper index should occur well before the coolant level between the Seal Wheels reaches the centerline of the wheels. An index will last only until the coolant level drops off. The sequence of events is as follows:

- A. Level sensor sends signal.
- B. Control starts Index Motor.
- C. Drive Shaft rotates. Drive shaft is fitted with sprockets made to drive mesh belting inside unit.
- D. The mesh belting rotates the seal wheels insuring that the media moves forward.
- E. The media feeds out of the filter onto the discharge lip and into a media bucket provided. Particulate captured by the media is carried with the media.
- F. Coolant level drops.
- G. Coolant level drops below level sensor.
- H. Index motor stops. Control resets.

The indexing sequence is fully automatic. However, when a new roll of media must be introduced into the filter, there is a Manual Index Button. This button allows the media to be advanced while the remainder of the system remains non-operational.

## **Disposable Filter Media**

There are several sources for filter media, plus a variety of grades and filtration values. Alternate types may be experimented with as long as the width is correct for the filter unit and the roll diameter does not exceed 10.00 inches. Experimentation may lead to an optimum choice in that it has adequate filtration with a long duration between indexes providing media savings.

Jorgensen Conveyors supplies media determined to be the optimum for the application with each filter until.

Caution: Use of a media narrower than recommended may lead to particulate entering the Clean Coolant tank.

The media is monitored by a Low Media Sensor as well as a No Media sensor. The roll should be changed before the expiring roll runs out. Failure to change roll before fresh media is depleted may lead to particulate entering the clean coolant tank.

Media rolls must be manually changed over when necessary.

---

### **Notes**

## Section I. Identification of Major Components

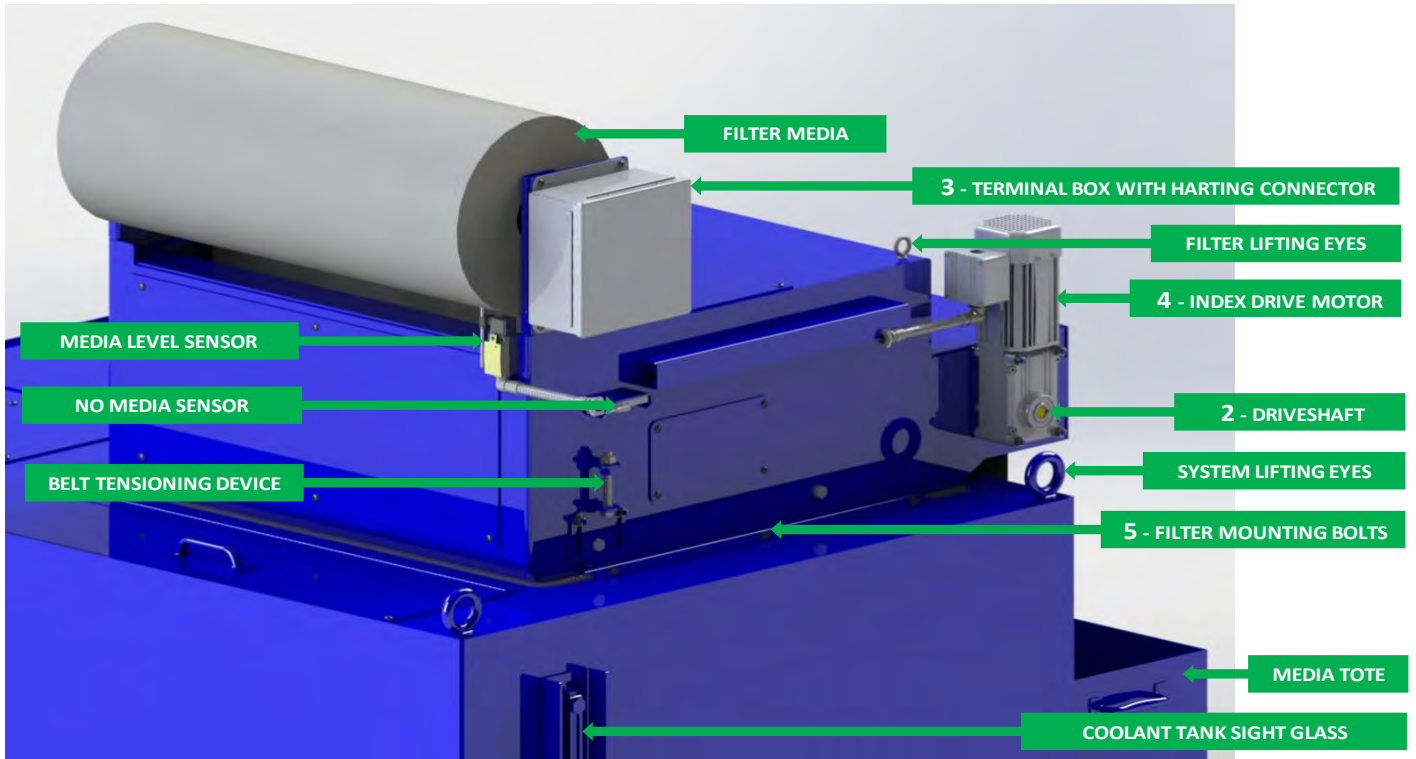

Fig. 1-1 Front and Drive Side of Filter

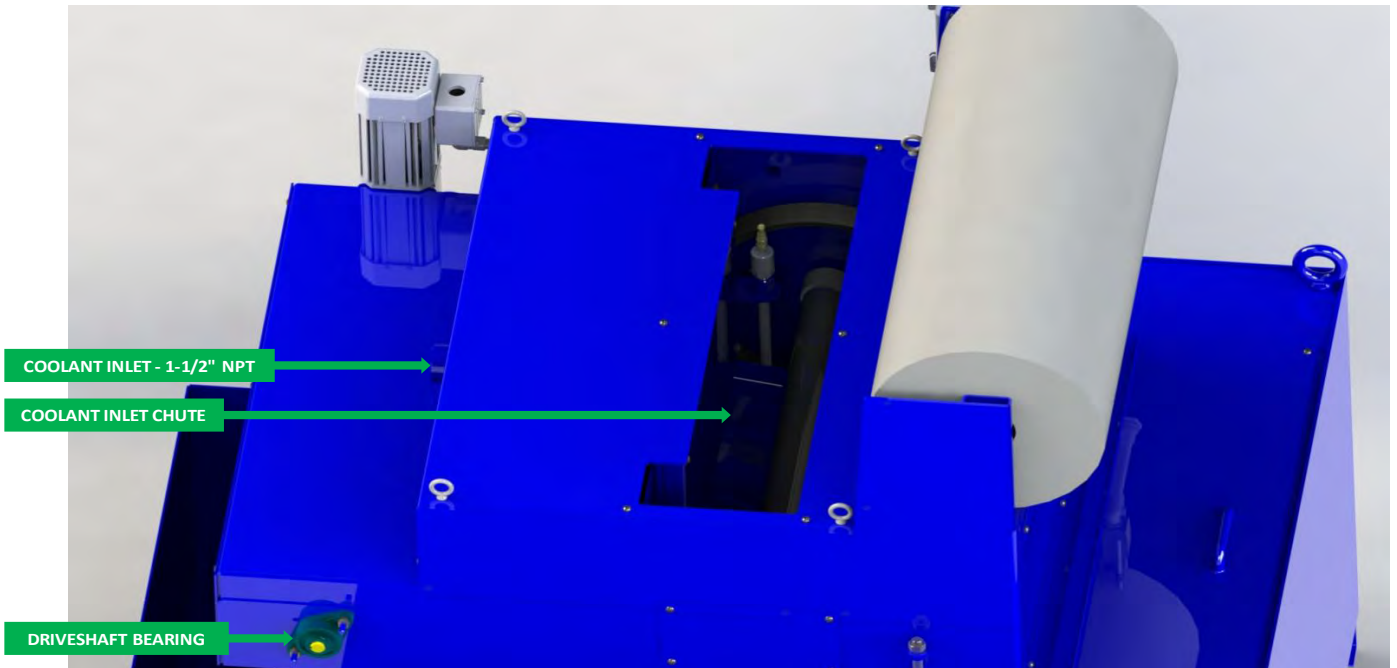

Fig. 1-2 Overhead View

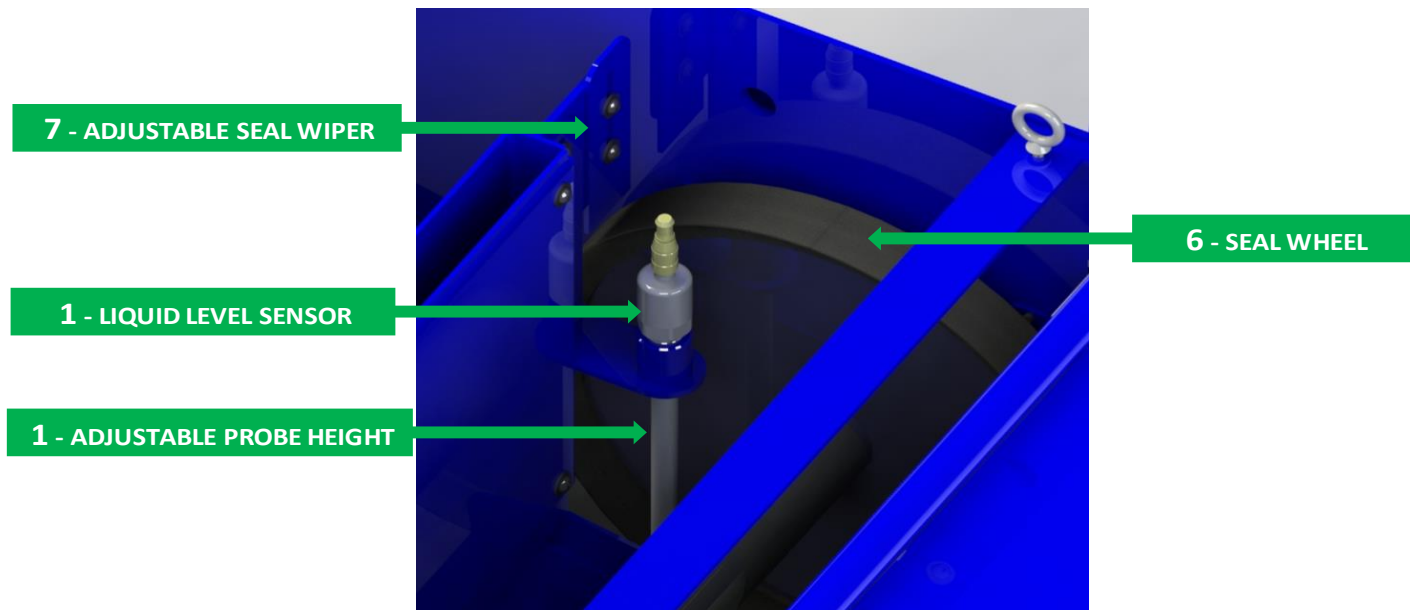

Fig.1-3 View of Internal Filter (Through Cover Access Opening)

## 1. Liquid Level Sensor

The Liquid Level Sensor controls the amount of liquid between seal wheels before an index. Raising the sensor increases the coolant level. The coolant level must be set below the paper discharge height to prevent spilling over.

Sensor is tested at Jorgensen Conveyors, Inc.

The switch operates on 18-30 VDC with a Supply Current of < 50 mA.

See Appendices.

## 2. Drive Shaft

The Drive Shaft is the only driven member within the Gravity Media Filter. All other shafts are fixed and serve as supporting shafts for live idler rollers. The Drive Shaft is polished and ground stock with a keyway running its full length and supports sprockets engaging the mesh belting. The media is supported and driven through the filter by the mesh belting in conjunction with the seal wheels.

The drive shaft is supported on non-drive end by a two-bolt flange bearing and is coupled to a gearmotor on the other.

### 3. Terminal Box and Harting Connector

All electrical devices integral to the Filter alone are electrically terminated within the Terminal Box located on the drive side. The Harting connector allows the filter to be electrically disconnected from the remainder of the system, if, for maintenance reasons, the filter must be lifted from the tank.

See Electrical Drawings for detailed information on Terminal Box.

### 4. Index Drive

The Index drive is a 115, 1 Ph, 60 Hz, 1/15 HP gearmotor mounted directly to the filter. The gearmotor is not user serviceable and should be replaced in the event of failure.

### 5. Filter Mounting Bolts

There are six (6) mounting bolts, three per side, securing the Filter to the Tank. In the event the Filter must be separated from the tank for maintenance, all six bolts must be removed.

### 6. Seal and Seal Wheel Assembly

The Seal Wheel Assembly consists of four components: End Bumper, Seal Wheel, Seal and Cross-shaft. The End bumpers and Seal Wheels are mounted by a 5/8-11 x 3-1/2 Socket Head Capscrew. Unless damaged through mishap, or seals are scheduled for replacement, there is no reason for disassembling the Seal Wheel Assembly.

The Seal Wheel Assembly is suspended inside the Filter by the mesh belting. The mesh belting surrounds the lower 180° of the seal wheels. In the event the Seals become worn or damaged, they may be replaced. See Maintenance Section.

### 7. Seal Wiper

The Seal Wiper is a means to keep large particles from sticking on the seals and eventually becoming trapped between the seal and media. Trapped particulate of any great size will allow fines to creep underneath the seal and enter the clean coolant stream.

The Seal wiper is adjustable as to relative angle against the seal, and for depth of Scraper Blade. As scrapers wear, they may require adjustment and eventually replacement.

## Section II. Operation

Operation of the Jorgensen Conveyors Gravity Media Filter is straight forward. Beyond periodic replenishment of filter media, the unit takes care of itself.

### Threading of Media

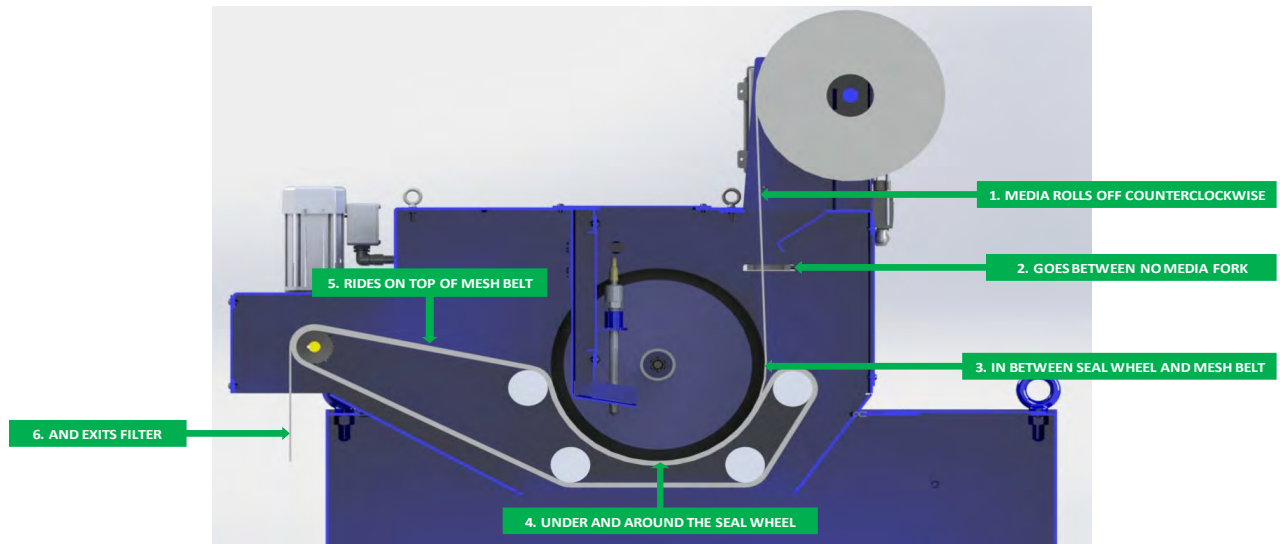

Fig. 2-1 Path of Media through Filter

To thread media from a fresh roll, the following steps may be used.

- A. Roll should be installed in a manner allowing media to peel off when roll is rotated down into filter.
- B. Media end should be straight allowing both seal wheels to grab.
- C. Guide end of media into seal wheels..
- D. Using Manual Advance Pushbutton, advance media through Filter. Once media is caught between seal wheels and mesh belting, it will feed through unit without further intervention.
- E. Allow media to hang below discharge lip.

### Standard Control

Jorgensen Conveyors provides a Standard Junction box with terminals that the electrical components are wired to. Also included is a Harting Connector located on the side of the enclosure for the customer to interface with.



## **Optional Control**

If the customer requires a stand-alone system , Jorgensen Conveyors can provide a control with logic to control the system by itself. The functionality and composition of the control will be based on the customer's requirements.

## **Notes**

---

## Section III Maintenance

### Removal of Seal Wheel Assembly

1. Remove Top Cover / Inlet Assembly
  - A. Remove (4) lifting eyes securing the top cover.
  - B. Remove (2) socket button head cap screws located on the same face as NPT inlet.
  - C. Disconnect Liquid Level Sensor cable through top coverplate, removing the (6) socket button head cap screws fastening it to the Top Cover (coverplate can be reattached once cable is disconnected).
2. Remove Seal Wheel Assembly
  - A. Wrap a lifting strap or chain around cross-shaft and secure
  - B. Using a crane or other suitable lifting device, raise assembly straight up until bottom of seal wheels clear frames.
  - C. Unless seals are to be replaced, do not rest assembly on seals.

For parts see Parts Section.

### Replacing Seal Wheel Seal

Under normal wear conditions, seals should be replaced in sets. The following instructions provide method for replacing seals. Also, refer to JCI Drawing 30-8761 in the Appendices.

1. Remove Seal Wheel Assembly from Filter.
2. Dismantle Seal Wheel Assembly by removing socket head capscrews from ends.
3. Remove old seal from seal wheel. Clean all rubber and adhesive residue from edge and faces of seal wheels.
4. Use lacquer thinner or other suitable cleaner to remove any oil or dirt from seal wheels.
5. Cut new seal material to length. Use table below for lengths. Insure that ends are cut square. This may be done with a razor knife, bandsaw, or other suitable method of cutting.
6. Clean out channel of new seal. Insure it is free of dirt, oil, or rubber particles.
7. Wrap seal around seal wheel. Insure seal is proper length and seats onto seal wheel.
8. Remove seal from wheel. Lay seal flat on work surface, channel up.
9. Apply adhesive directly into channel. Jorgensen Conveyors recommends Elmer's® Nano Glue for this purpose, however other brands may work as well.
10. Begin wrapping seal around seal wheel, insuring that seal is fully seated onto wheel. When seal is fully wrapped, apply a sparing amount of adhesive to seal ends.

11. Clamp seal so that it maintains position while adhesive cures. Aforementioned product requires 24- hour cure time.



Fig. 3-1 Seal Material

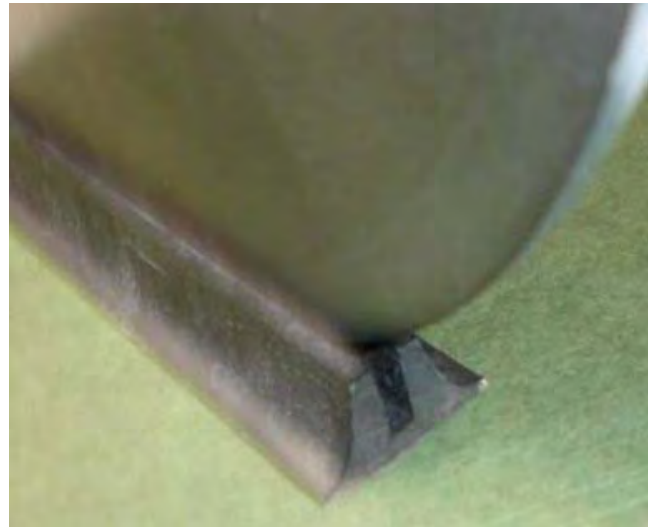

Fig. 3-2 Seal Wheel in Channel of Seal

<b>Size of Filter (GPM)</b>	<b>Length of Seal Wheel Seal (inches)</b>
<b>30</b>	<b>41.062</b>
<b>60</b>	<b>61.656</b>
<b>90</b>	<b>93.062</b>

Table 3-1 Seal Lengths

### Removal of Idler Roller Assembly

1. Remove Seal Wheel Assembly
2. Mesh belting should now be slack.

Note: Mesh Belting is endless. While it may be broken, it is recommended that it not be unless necessary.

3. Remove capscrews securing Roller Assembly to be removed. Capscrews are on outside of frames, (1) either side. See Figures 3-6 and 1-1.
4. Reaching under the mesh belt, lift the roller and center shaft upward toward top of frames. When clear of frames, slide from underneath mesh belting.

For Part Numbers see Parts Section

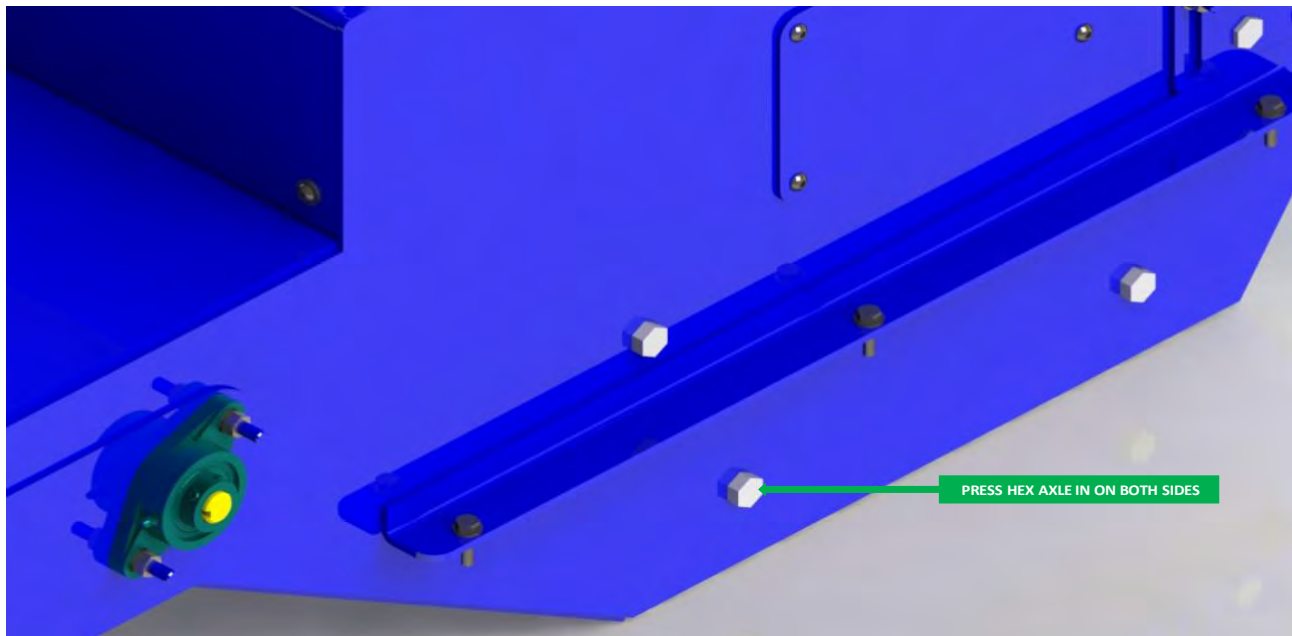

Fig. 3-3 Idler Roll Assembly

## Replacing Drive Shaft Bearing

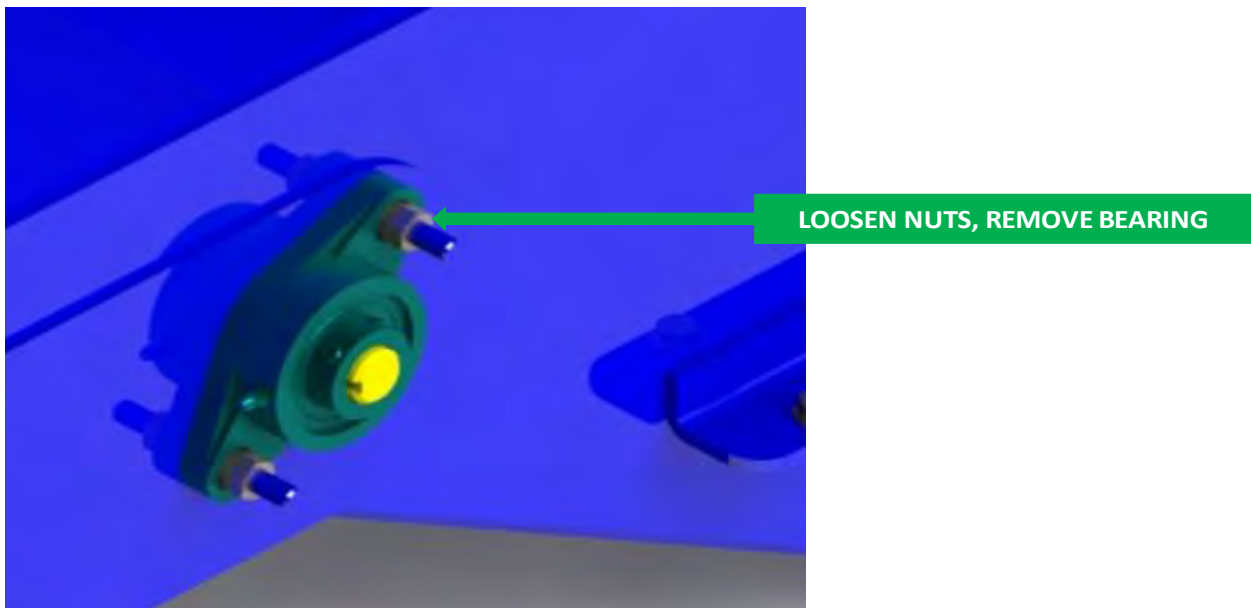
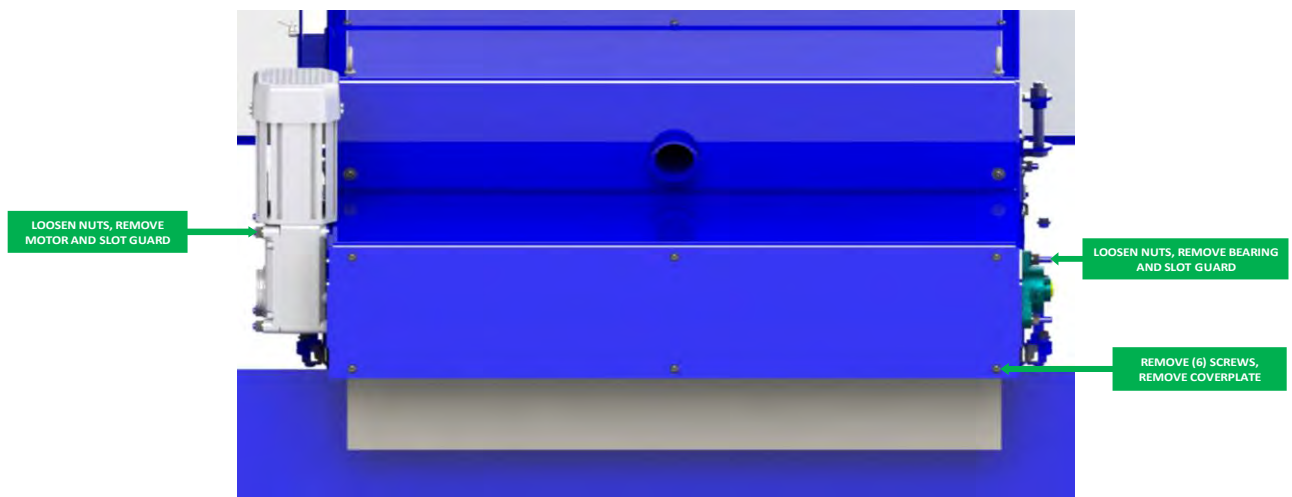

Fig. 3-7 Drive Side Bearing

1. Removal of Non-Drive Side Bearing
  - A. Loosen (2) setscrews fastening bearing to Drive Shaft
  - B. Remove (2) Hex Nuts fastening bearing to unit
  - C. Remove Bearing from Drive Shaft
  - D. Drive Shaft will drop slightly after bearing is removed.
  
2. Replacement of Non-Drive Side Bearing
  - A. Lift Drive Shaft slightly, centering it between the mounting studs.
  - B. Slide bearing onto shaft and studs. Push until fully seated onto shaft.
  - C. Tighten setscrews fastening bearing collar to shaft
  - D. Replace Hex Nuts and tighten.

## Removal of Drive Shaft

1. Remove Seal Wheel Assembly  
Refer to above section.
2. Loosen (2) setscrews fastening Non-Drive Side Bearing to Drive Shaft and remove bearing and same side filter slot guard
3. Loosen (4) nuts that fasten Gearmotor to filter and remove motor and same side filter slot guard
4. Loosen (6) socket button head cap screws on end coverplate and remove coverplate.
5. Pull shaft assembly with belt towards open end.
6. Once sprockets are outside filter body, slide shaft out from inside belt.



Note: Mesh Belt Sprockets are directional. Before removing sprockets from drive shaft, note manner in which they are installed. If replacing sprockets, new sprockets must be installed in correct running direction.

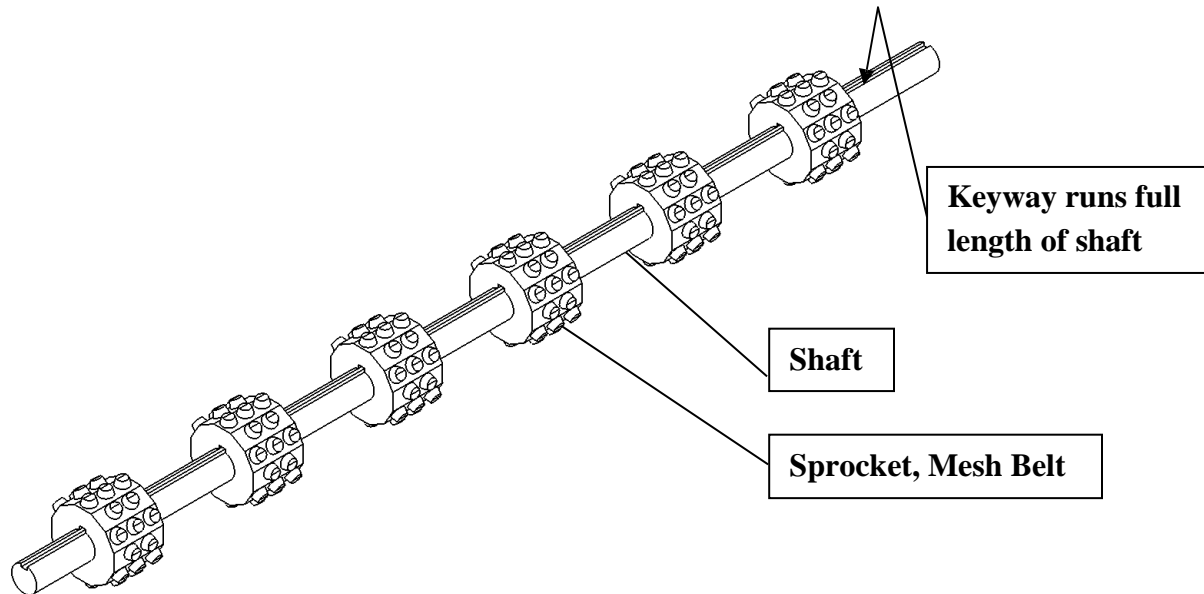

Fig. 3-8 Drive Shaft w/o Drive Sprocket and Bearings

### Removal of Mesh Belting

1. Remove Seal Wheel Assembly  
Refer to above section.
2. Remove Drive Chain  
Refer to above section.
3. Drive shaft should rotate freely with mesh belting
4. Locate joint. Weld on edge will look significantly different than others.
5. Grind weld off – both sides – until Crimped Connector is free
6. Remove Crimped Connector – belt will part  
Note: Crimped Connector runs across the mesh belting from drive side to non-drive side.
7. Take end of belt nearest discharge of Filter unit and begin pulling out of unit until all of mesh belt has been removed from unit.

### Replacement of Mesh Belting

Before installing new mesh belting, check that all idler rollers and bearings are serviceable and that drive shaft sprockets and bearings are serviceable. Replace any part that seems questionable while the mesh belting is removed from the Filter Unit.

1. Install new mesh belting by feeding from drive end of unit using Drive Shaft Sprockets to help feed. Insure that belting thread underneath bottom idlers, around nose idler and across top of discharge idlers.
2. Join new belting in area approximately where Seal Wheel Assembly would normally reside.

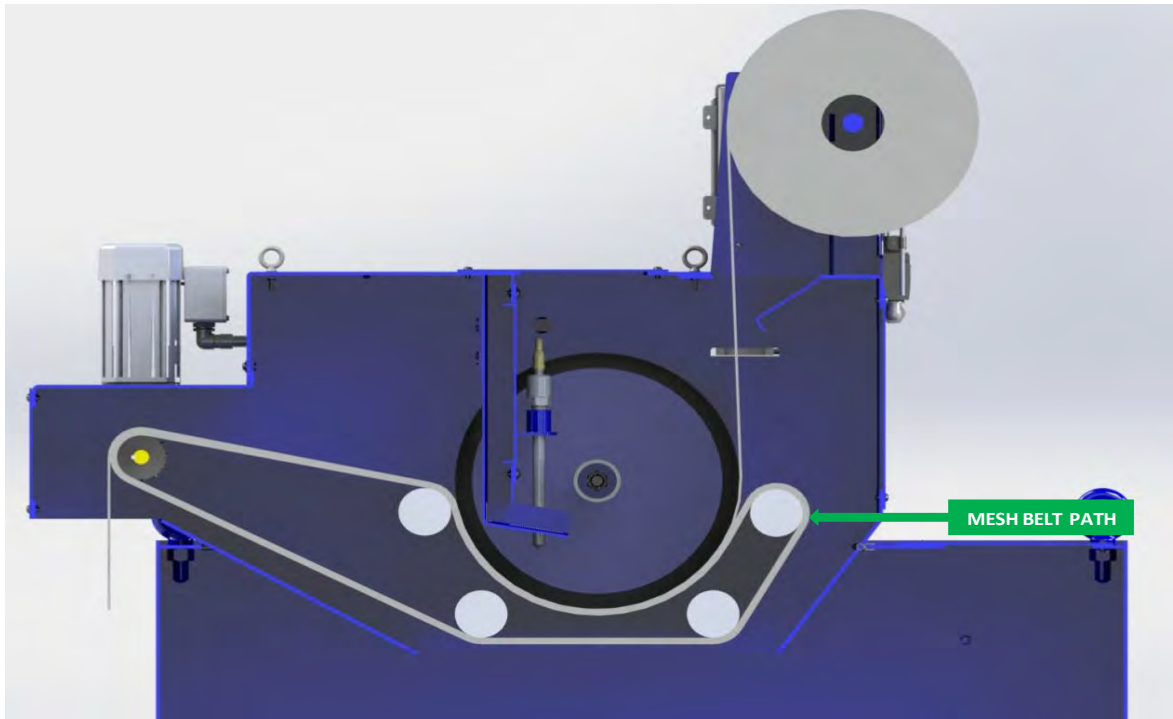

Fig. 3-9 Path of Mesh Belt through Filter

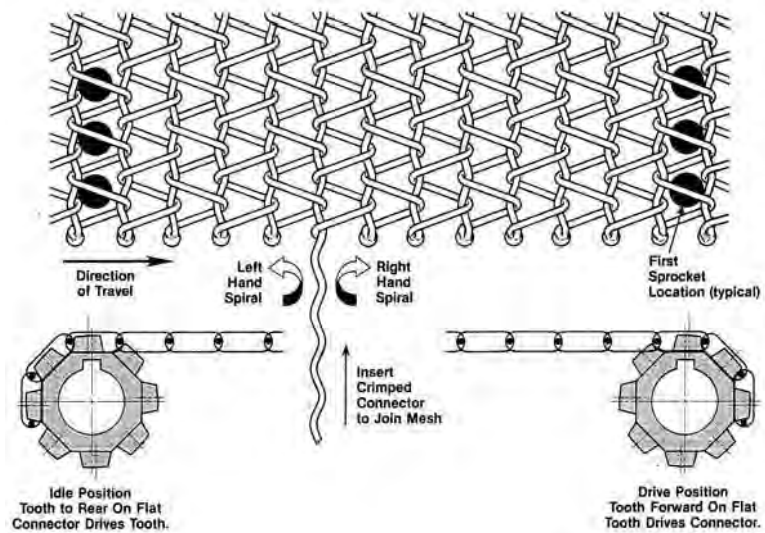

Fig. 3-10 Installation of Mesh Belt



3. Insure that belting is flat, straight and that no spirals have rotated or turned. Correct as necessary.
4. Insure belting is facing proper direction for travel.

Note: Fig. 3-10 shows belting as installed into a system with a drive and driven shaft. As the

Jorgensen Conveyors Gravity Media Filter uses plain rollers as idlers, pay attention to the drive roller on the figure's right hand side.

5. Slip a new Crimped Connector from belt manufacturer into belting connecting the two ends of the belt together.
6. Weld both ends of the Crimped Connector.
7. Using Drive Shaft, rotate belting, insuring all of mesh engages sprockets properly.
8. Reassemble remainder of filter.

#### **Section IV. Spare Parts**

Spare Parts drawings will be supplied. Please contact Jorgensen Conveyors, Inc. Please contact Jorgensen Conveyors, Inc. for replacement or spare parts.

---

#### **Notes**

## WARRANTY

Jorgensen Conveyors, Inc. guarantees the material of our manufacture against defects in material or workmanship under normal and proper use for one year in service or eighteen months from shipment, whichever occurs first. Material which we purchase can be guaranteed by use only to the extent of the original manufacturer's guarantee. We shall not be held liable for damages or delay caused by defective material, or contingent claims of any kind arising from loss of production owing to failure of shipment. Our obligation under this warranty is limited to furnishing new or replacing defective material without charge f.o.b. factory. No allowance will be made for repairs or alterations unless made with our written consent.

Caution should be used in the care and application of our products as the guarantee recited above does not apply where lack of proper maintenance or misapplication exists. We will not be liable for improper storage or handling of our products prior to placement in service.

The within equipment will be specifically designed and manufactured for and will be sold to purchaser for the sole purpose of transporting and conveying raw materials, work in process and finished goods of purchaser. Purchaser does hereby agree to exonerate, indemnify, defend and hold seller harmless of and from all loss, liability and damages which may be suffered by or asserted against the seller, and all costs and expenses which seller may incur because of any claim or claims which may be asserted against seller by any person for death or injury to anyone sustained while riding or attempting to ride upon said equipment.

## **A word about Jorgensen Conveyors . . . .**

Founded in 1950, Jorgensen Conveyors has evolved into a leading machine tool conveyor specialist, supplying high quality, custom designed conveyor and coolant filtration systems to a variety of leading machine tool builders and end user manufacturers in the metal working industry.

A key factor in this growth was the development of our patented chain belt design. None of the parts are welded. Instead, each part, made of extra heavy gauge steel, is held by an axle that passes through the part. If a part should become damaged, the belt assembly is completely detachable so that the part can be replaced quickly. This design also features fewer parts, making it more cost effective.

What really sets Jorgensen apart today is our design capability across the broad range of chip removal applications for CNC (Computer Numerically Controlled) machine tools. Today, Jorgensen Conveyors supplies chip conveyors and coolant filtration systems to machine tool builders and end users in manufacturing sectors such as automotive, heavy equipment, and aerospace, and to contract machine shops that supply parts to these manufacturers.

Jorgensen has also built its reputation in the industry with responsive warranty service. It is a service-oriented philosophy that worked in 1950, works today, and will keep working into the next century.

JORGENSEN CONVEYORS, INC. • 10303 N. Baehr Road • Mequon, Wisconsin 53092-0156  
P.O. Box 09156  
Phone: 262-242-3089  
Fax: 262-242-4382  
[www.jorgensenconveyors.com](http://www.jorgensenconveyors.com)