

OPERATOR MANUAL

Disposable Media Conveyor Vacuum Filtration Unit

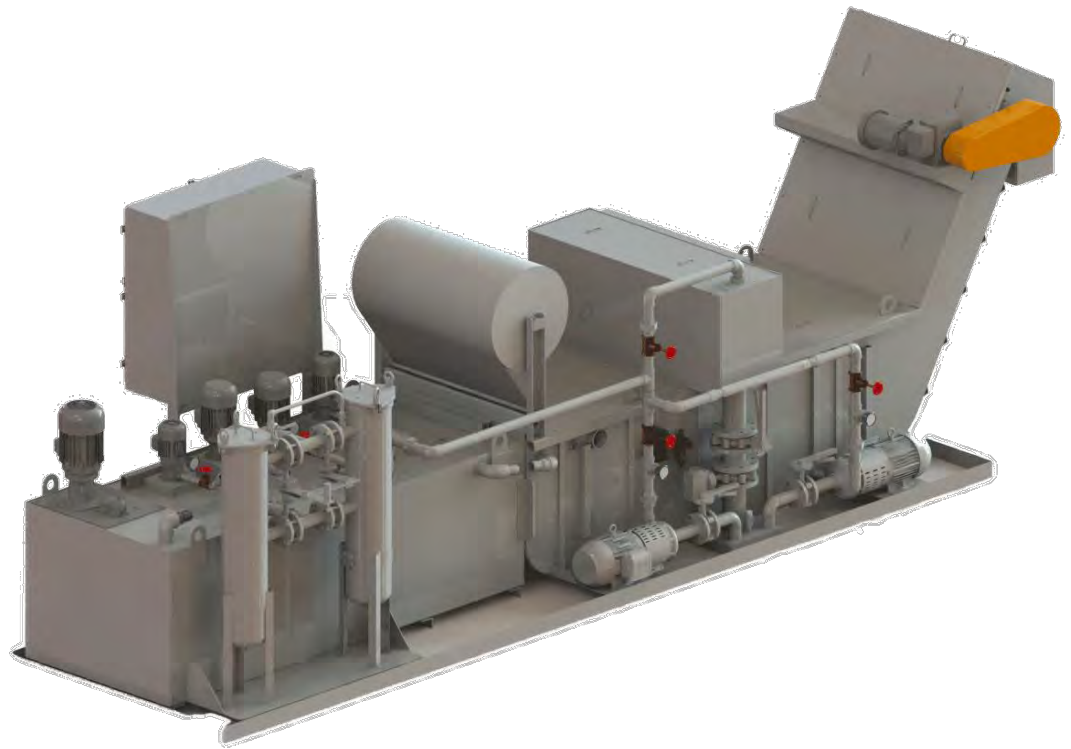

Jorgensen[®]
CONVEYORS, INC.

Partial member of
AMT
ADVANCED
MANUFACTURING TECHNOLOGY
703-993-2900 • www.AMTonline.org



Bulletin No. 01-06 Rev 0816

WARNING:

Failure to comply with safety procedures in this manual places personnel health and safety at serious risk!

- **Do Not operate or perform maintenance on this equipment without reading the proper instruction manuals pertaining to its safe operation or repair.**
- **Never work on, or around machinery without wearing proper personal safety equipment.**
- **Never remove covers or guards from machine while electrical power is connected, or air pressure is applied.**
- **Never attempt to repair or adjust pressure devices without disconnecting electrical power and draining all liquid from interconnecting hoses, pipes, or tubes.**
- **Never operate machinery with safety covers removed.**

TABLE OF CONTENTS

Introduction	1
Description	1
GENERAL	1
CONTROL PANEL (if supplied).....	1
DISPOSABLE FILTER MEDIA	1
CLEAN TANK.....	5
PNEUMATICS	5
General	5
Vacuum Break Circuit	5
Installation	6
Start-Up Instructions	6
SET-UP OF EXTERNAL DEVICES	7
Filtration Unit Low Liquid Level Sensor.....	7
Filtration Unit High Liquid Level Sensor	7
Clean Tank Low Coolant Level Sensor (if provided)	8
Vacuum Break Valve	8
Service & Maintenance	8
INSPECTION AND ADJUSTMENT OF HEADSHAFT	8
REPLACEMENT OF HEADSHAFT SHEAR PIN (if provided)	9
RATCHET SLIP CLUTCH (if provided).....	10
Adjustment.....	10
REMOVAL OF THE HEADSHAFT ASSEMBLY	11
CHANGING DISPOSABLE FILTER MEDIA.....	11
REDUCER LUBRICATION.....	11
Lubrication.....	11
DRIVE CHAIN ADJUSTMENT	12
DRAG CHAIN ASSEMBLY INSTALLATION AND ADJUSTMENT	12
Removal.....	12
Installation	12
LUBRICATION.....	13
Troubleshooting	14

Notes

Introduction

The Jorgensen Disposable Media Conveyor Vacuum Filtration Unit is used to clean coolant generally used in applications involving grinding operations or other applications where fine particles are created.

Description

GENERAL

Refer to Figures 1 and 2 for identification of major components of the Jorgensen Disposable Media Conveyor Vacuum Filtration Unit, and a general flow diagram of system operation.

Coolant in the unit is drawn by vacuum through a disposable filter media using a system pump and motor. Clean coolant from the system pump is channeled to both the machine (depending on the application, this may be a low-pressure pump that floods the grinding tool) and the clean tank.

Flow rates from the system pump discharge to the clean tank are regulated by a flow valve located in the clean tank intake line.

The clean tank provides coolant to the vacuum break valve, which breaks the vacuum in the vacuum chamber preparatory to drag chain and filter media indexing.

The clean tank may be equipped with a low-liquid-level indicator/sensor, and an overflow pipe that drains excess coolant back into the filtration unit.

The drag chain and disposable filter indexes to expose fresh media to the coolant typically under either of two conditions: 1) when the system control times out, or 2) the system indexes when the vacuum within the system exceeds a preset level.

In either case, the vacuum break valve is opened by retraction of the vacuum break cylinder. This, in turn, causes the system pump to flood, thereby breaking the vacuum in the vacuum chamber. This also causes the filter media to raise slightly to avoid damaging the filter media as the media and drag chain are indexed.

Immediately after the vacuum breaks, the motor is actuated to index the drag chain a prescribed distance.

The sequence of events required to initiate vacuum break and drag chain indexing is automatic.

CONTROL PANEL (if supplied)

Refer to Figure 3.

Emergency Stop – Completely removes power from all controls.

Conveyor Fail – Lights when conveyor drive has failed.

Conveyor Fail Reset – Allows resetting after the conveyor drive failure has been repaired.

System On – Indicator lights when system is powered.

Stop System – Removes power from all systems within the filtration unit.

Start System – Applies power to all systems within the filtration unit.

Vac Time / Vac/Jog – Vacuum or time to index / vacuum only to index / moves conveyor to load media.

Low Media –Indicates that the roll of disposable media is low and needs to be replaced.

Media Low Light – Located on top of the control panel, the flashing light indicates that the filter media roll is low and needs to be replaced.

High Liquid Level (Warning Light) – Indicates that the coolant in the load section of the filtration unit is high.

Low Liquid Level (Warning Light) – Indicates that the coolant in the load section of the filtration unit is low.

DISPOSABLE FILTER MEDIA

Low Media Sensor. Monitors the amount of media remaining on the roll. Activates the Low Media Light on the control panel, and activates the warning light on top of the control panel.

The disposable filter media comes in rolls, which must be manually changed (installed) when the Low Media light comes on.

Disposable Filter Conveyor

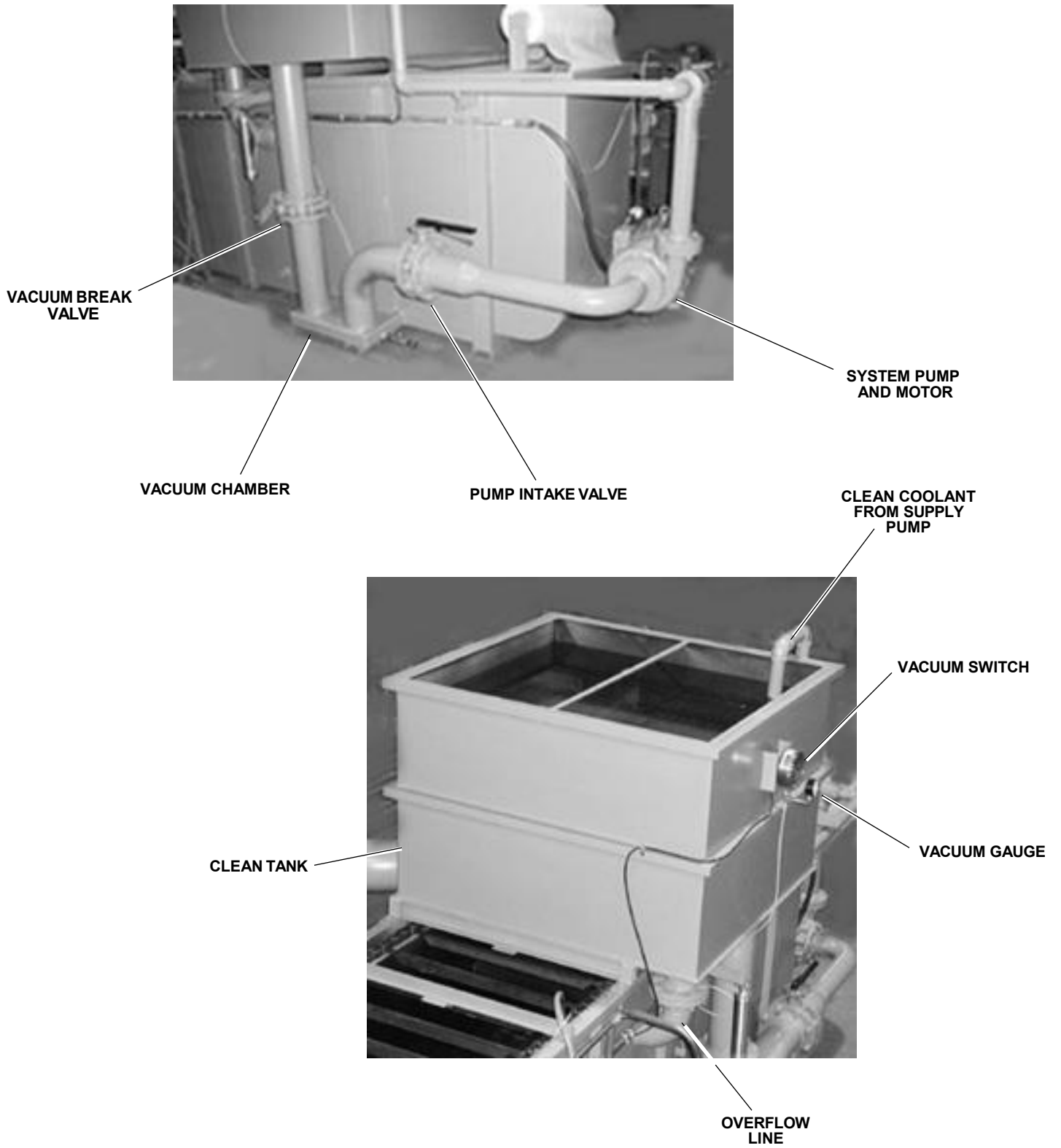

Figure 1. Major Components

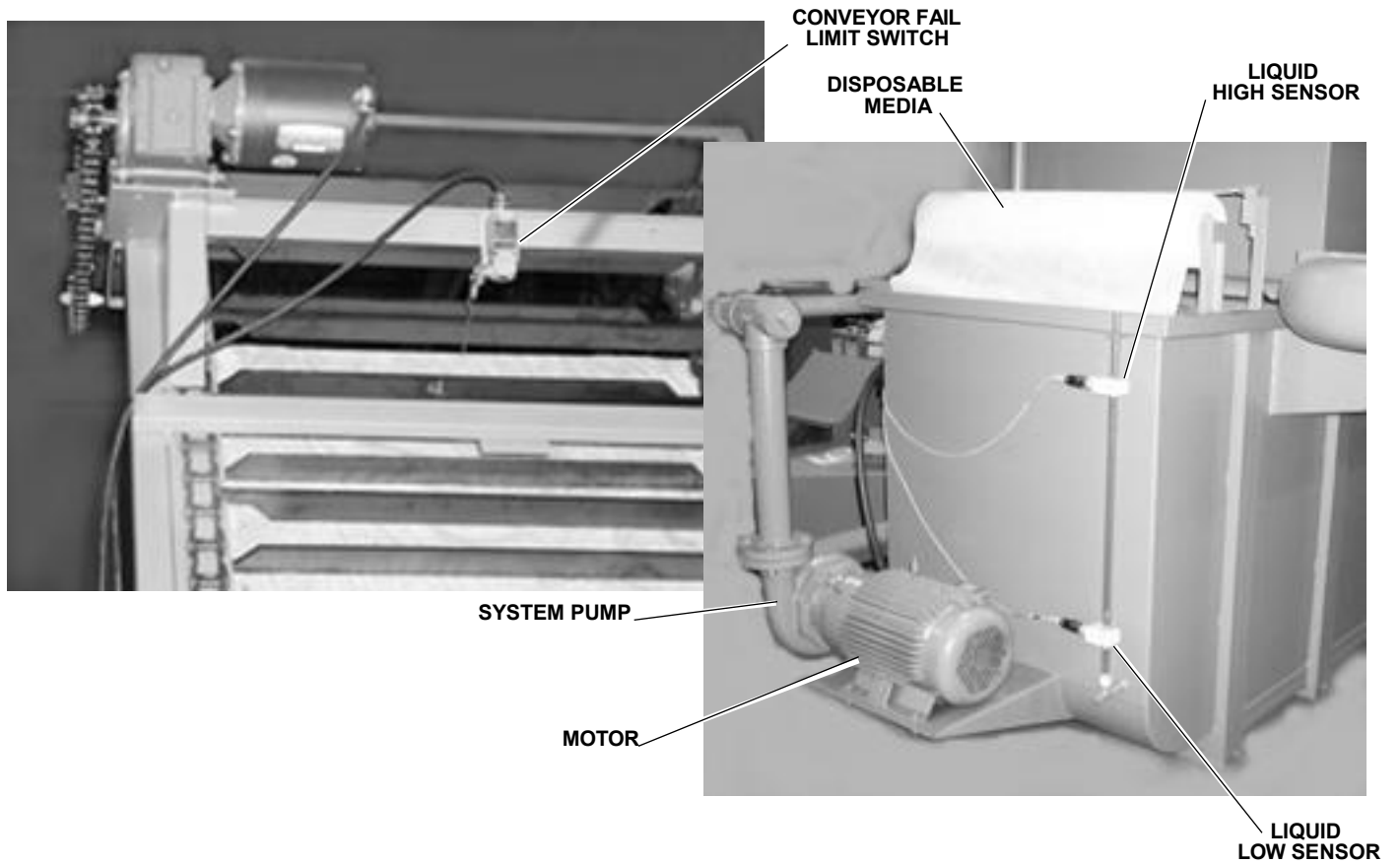
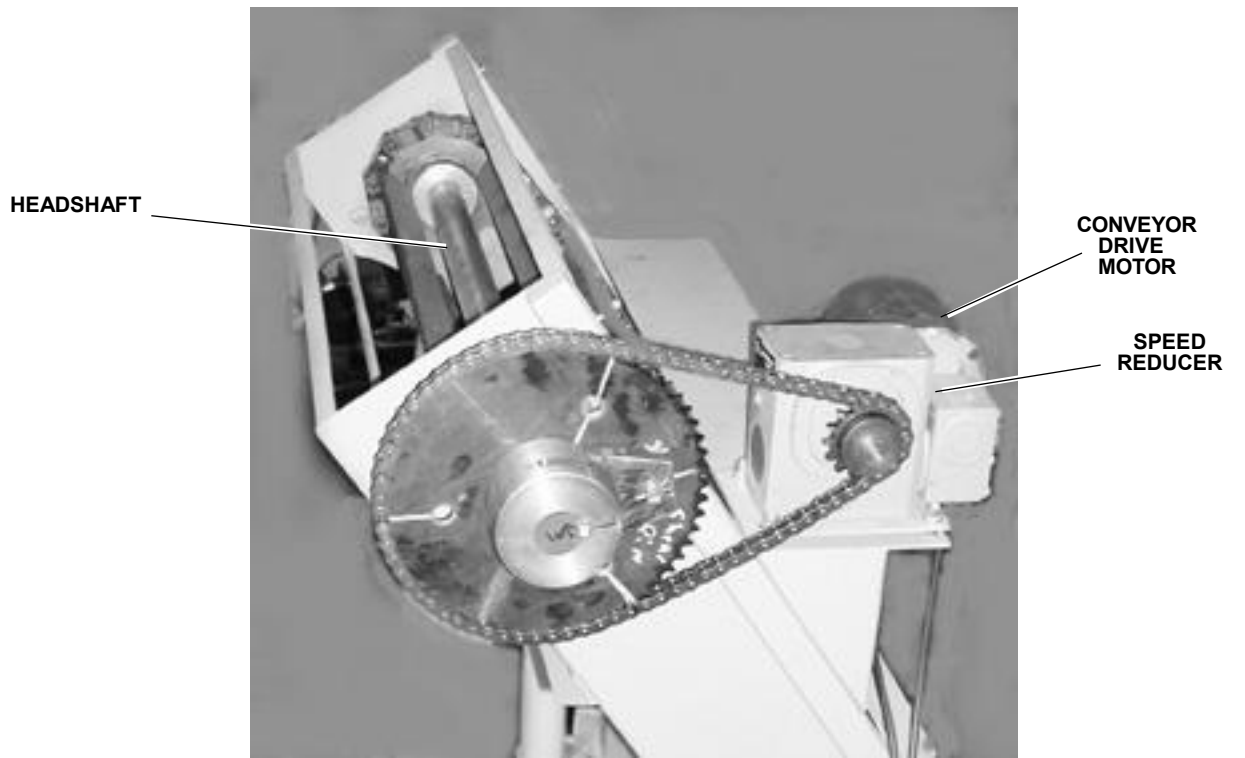

Figure 1 Continued. Major Components

Disposable Filter Conveyor

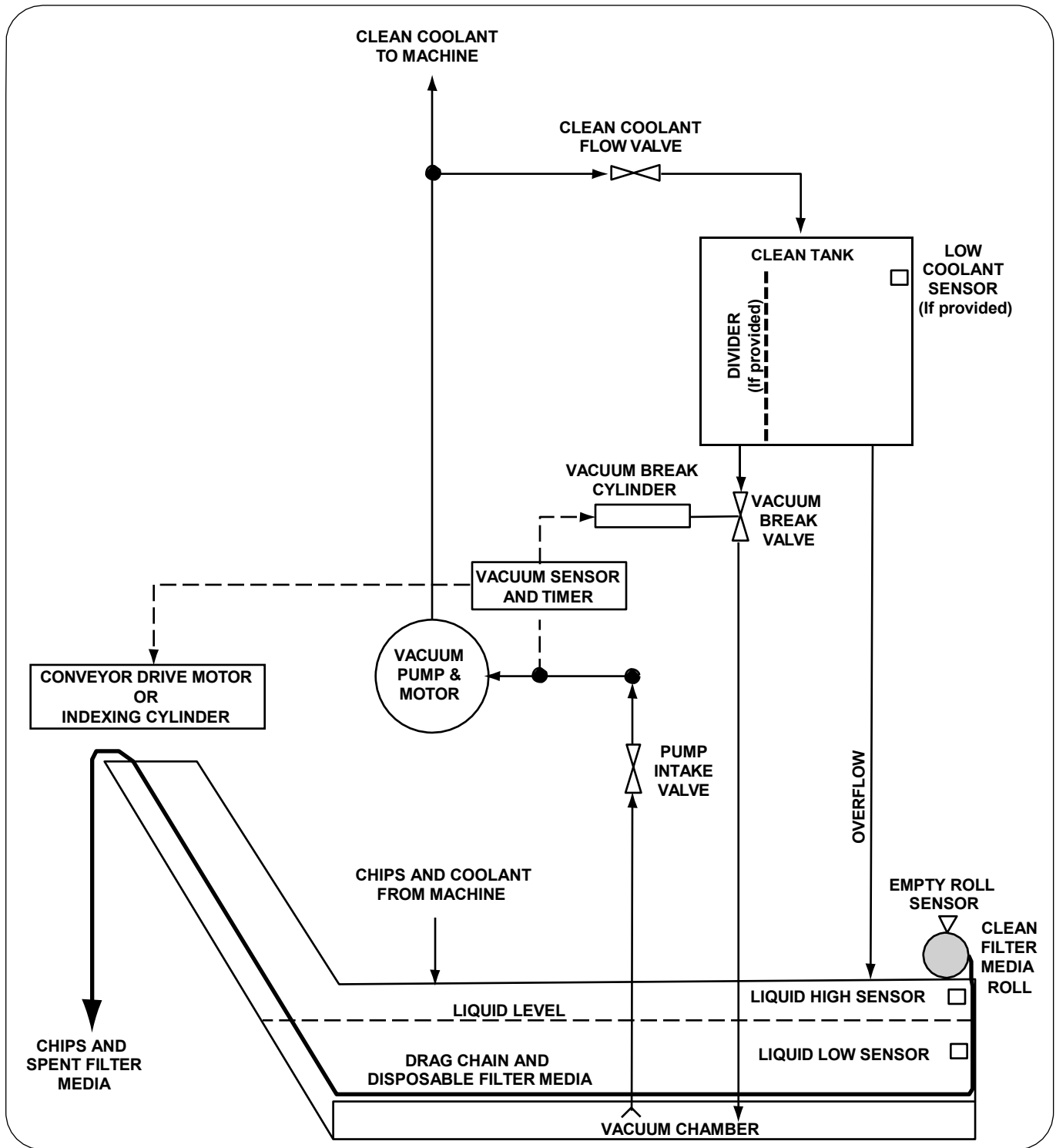

Figure 2. System Flow Diagram

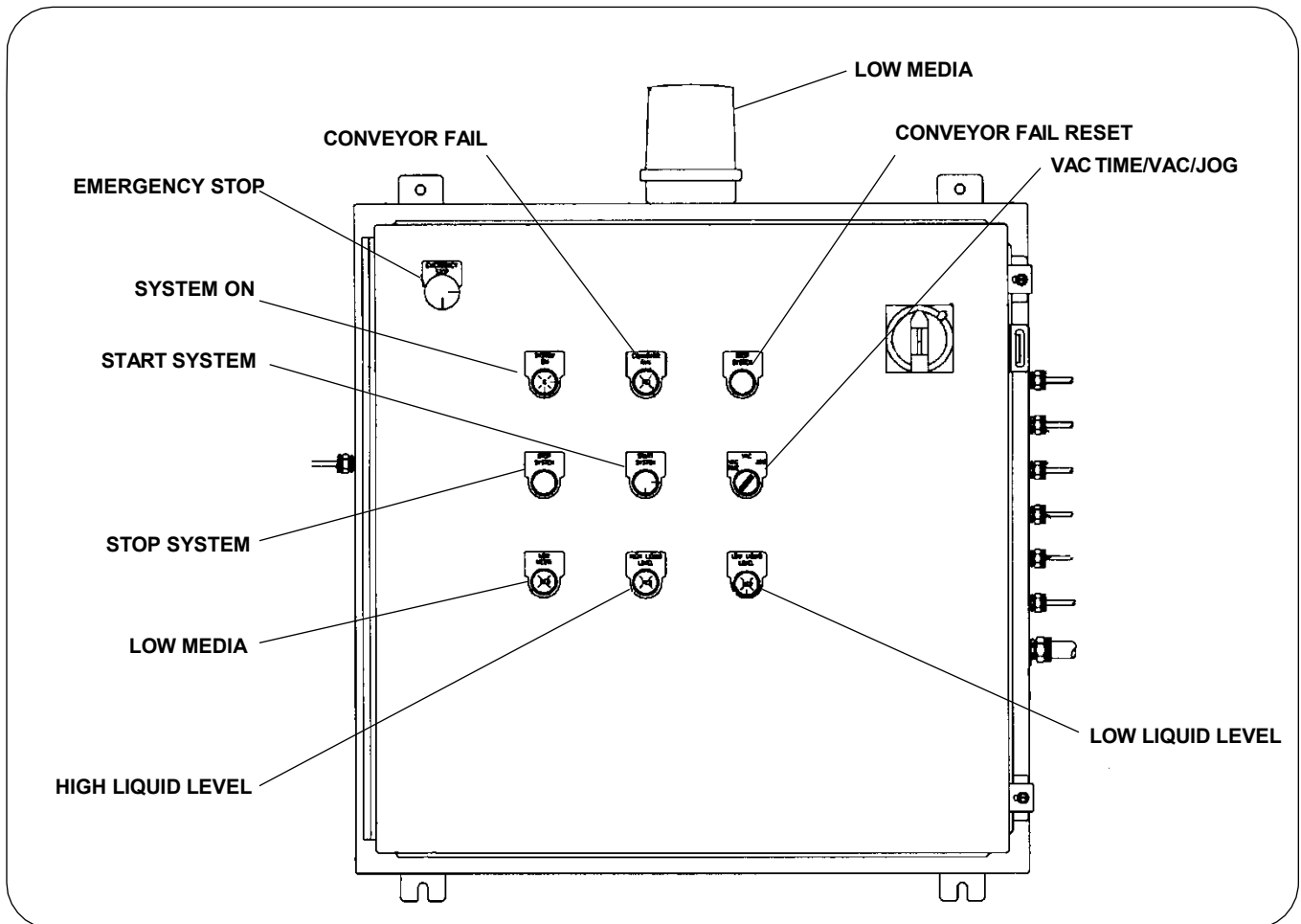

Figure 3. Control Panel

CLEAN TANK

Clean Coolant Flow Valve – Controls coolant flow rate from the system pump to the clean tank. Adjust to maintain the liquid level in the tank. May require readjustment if other adjustments are made in the system.

Vacuum Break Valve – Controls the flow of coolant to the vacuum chamber. Adjust to allow minimum required.

Pump Intake Valve – Used in installations where the system pump is located at a lower level than the coolant level in the filtration unit. Closing the valve prevents coolant flow in situations when the pump is removed during maintenance.

PNEUMATICS

General

The pneumatic system generally controls vacuum break. Optionally, the system can provide indexing if a pneumatic cylinder is used to index the drag chain instead of an electric motor.

Vacuum Break Circuit

A solenoid valve in the pneumatic circuit controls the vacuum break cylinder position; either fully extended or fully retracted.

The solenoid valve, in turn, is controlled by a timer. Power “ON” switches the valve, power “OFF” allows spring return to the rest position. The cylinder rod is

extended at rest, which, in turn, closes the vacuum break valve. This valve is used during drag chain indexing.

When the valve is powered, its internal spool shifts, causing the cylinder to retract. Cylinder movement opens the vacuum break valve, allowing coolant to flow from the clean tank, flooding the vacuum chamber. (See Figures 1 and 2.)

Installation

The Vacuum Disposable Media Conveyor filtration unit is shipped fully assembled.

- In some cases the unit is small enough to permit lifting with a fork lift. Some units are large and require the use of a crane. As a safety precaution, be sure to use the proper lifting device to unload the filtration unit.
- Uncrate the unit carefully, and inspect for damage that may have occurred during transit. If damage has occurred, notify the carrier immediately.
- Review this manual in its entirety. If you have any questions, call Jorgensen Conveyors immediately.
- This unit has been run-in and tested in our facility. However, transportation can affect factory settings. If necessary, adjust the unit as directed in this manual.
- Check for and remove any loose material in the unit, especially from the bottom of the filtration unit. A Final Assembly drawing, specific to your filtration unit, has been provided. Refer to this drawing and use the following discussion as a guide on how to proceed with installation.

Refer to the Final Assembly drawing and proceed as follows:

1. Move the filtration unit into position up to the discharge from the machine.
2. Place blocking and shimming under the full width of the filtration unit to distribute weight uniformly. Be sure that the filtration unit is level.
3. Connect all piping and couplings, making sure all fittings are air tight. Air leaks in any part of the vacuum system are detrimental to system operation.

4. Refer to the pneumatic diagram and connect plant air (minimum 80 psi clean and dry) to the air filter/regulator. Set the control pressure regulator at 80 psi.
5. Refer to the electrical schematic (shipped in the electrical control cabinet, if supplied) and connect electric power to the fused safety disconnect.

Start-Up Instructions

The following instructions apply to initial start-up, and to start up after major shut down of the system for maintenance reasons.

WARNING: Failure to follow start-up instructions can cause personal injury!

- Individuals that are working on or around machinery must wear correct personal safety equipment.
- Be sure that all liquids are drained from interconnecting hoses, pipes, or tubes.
- Be sure that electric power is turned “OFF” and that the air supply is turned “OFF.”

Proceed as follows:

1. Be sure that the filtration unit is correctly installed and level.
2. Check and tighten all bolts, and inspect for obstructions that may hinder movement of the conveyor drag chain.
3. Verify electrical connections, turn on electrical power, and check rotation of the pumps and conveyor drive motor.

WARNING! Never remove safety covers or guards from the unit while electrical power is connected, or when air pressure is applied.

4. Dry run the conveyor system to verify mechanical operation (i.e., without pumps) to assure that the conveyor runs properly.

NOTICE: Be sure that the pumps do not operate during the dry run procedure to avoid damaging the pump seals.

5. Fill the filtration unit with coolant to its operating level as follows:
 - Fill the filtration system until the coolant level in the sight glass is just below the upper level.
 - Fill the clean tank until the tank is completely filled.
 - Prime the pump(s).
 - After initial start-up, coolant may need to be added as coolant carrying lines or hoses fill.
 - A balanced system should not overflow at shut-down, nor should any pump starve during operation.
6. Be sure that the vacuum break valve is closed (cylinder extended), and set the clean coolant flow valve to the OPEN position.

Caution: Coolant that is spilled on the floor creates slippery and hazardous conditions. Clean the floor of any spills or leaks immediately.

7. Push the START button on the remote or machine panel. The system pump will start.

SET-UP OF EXTERNAL DEVICES

Filtration Unit Low Liquid Level Sensor

Proceed as follows (see Figure 4):

1. Adjust the low liquid level sensor height with the system operating and with normal coolant flow.
2. Measure the height of the coolant while the system is operating under normal conditions. Generally, the minimum operating coolant level should be approximately 10 inches above the top of the vacuum chamber.
3. Adjust the low liquid level sensor height so that the light on the control panel activates when the coolant level falls to 30 inches above the vacuum chamber.
4. Low liquid level sensor **sensitivity** can be adjusted as follows:
 - A. Mark the position of the sensor (Step 3) on the sight glass.
 - B. The low liquid level sensor is normally closed, held open by the presence of coolant. Establish a worst case condition to cause a false OFF signal by moving the sensor above the level of the liquid

coolant in the sight glass so that the sensor “sees” only moisture.

C. Turn the potentiometer clockwise (CW) until the LED is OFF. Then turn the potentiometer counter-clockwise (CCW) until the LED just turns ON.

D. Move the sensor downward below the level of the liquid in the sight glass. The LED should be OFF. Turn the potentiometer (CCW) until the LED turns on.

E. Turn the potentiometer (CW) 1/2 turn. The sensor is now set.

F. Return the sensor to its original position (Step A).

Filtration Unit High Liquid Level Sensor

Refer to Figure 4 and proceed as follows:

1. Adjust the high liquid level sensor when the system is shut down and the coolant level is balanced.
2. The high liquid level sensor should be set so that the light on the control panel activates before the coolant overflows the filtration unit.
3. High liquid level sensor **sensitivity** can be adjusted as follows:
 - A. Mark the position of the sensor (Step 2) on the sight glass.
 - B. The high liquid level sensor is set for normally open operation. Establish a worst case condition to cause a false ON signal by raising the sensor

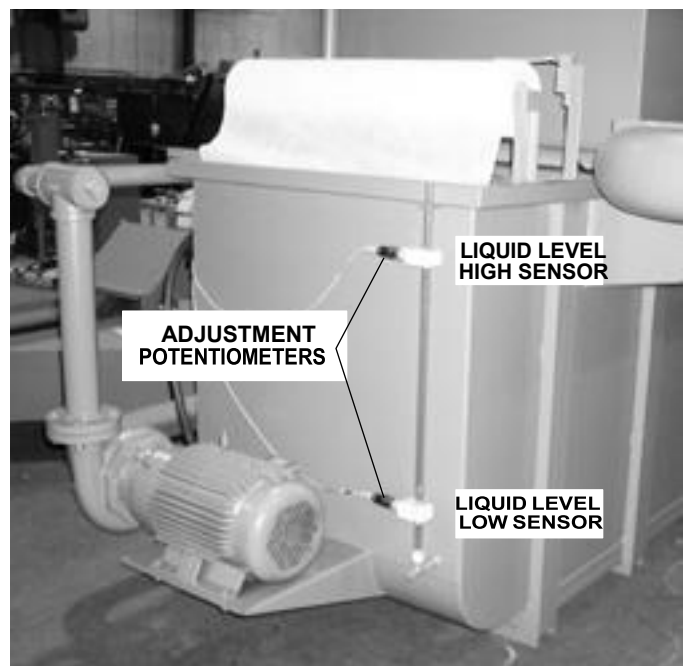

Figure 4. High and Low Liquid Level Sensors

Disposable Filter Conveyor

above the level of the liquid coolant in the sight glass so that the sensor “sees” only moisture.

C. Turn the potentiometer clockwise (CW) until the LED is ON. Then turn the potentiometer counter-clockwise (CCW) until the LED just turns OFF.

D. Lower the sensor below the level of the coolant in the sight glass. The LED should be ON. Turn the potentiometer (CCW) until the LED turns off.

E. Turn the potentiometer (CW) 1/2 turn. The sensor is now set.

F. Return the sensor to its original position (Step A).

Clean Tank Low Coolant Level Sensor (if provided)

In some units, the clean tank may be divided into two sections, separated by a divider: 1) a vacuum break section, and 2) a machine supply section. In this case, a low coolant level sensor would be provided. Adjust this sensor as follows:

1. The low coolant level sensor is located on a sight glass mounted on the clean tank. Correct coolant level within the tank should be determined while the filtration unit is in full operation.
2. Adjust the sensor to a height 1/2 inch below the divider.
3. Low liquid level sensor **sensitivity** can be adjusted as follows:

A. Mark the position of the sensor (Step 2) on the sight glass.

B. The low liquid level sensor is normally closed, held open by the presence of coolant. Establish a worst case condition to cause a false OFF signal by moving the sensor above the level of the liquid coolant in the sight glass so that the sensor “sees” only moisture.

C. Turn the potentiometer clockwise (CW) until the LED is OFF. Then turn the potentiometer counter-clockwise (CCW) until the LED just turns ON.

D. Move the sensor downward below the level of the liquid in the sight glass. The LED should be OFF. Turn the potentiometer (CCW) until the LED turns on.

E. Turn the potentiometer (CW) 1/2 turn. The sensor is now set.

F. Return the sensor to its original position (Step A).

Vacuum Break Valve

Proceed as follows:

1. With the system fully operational the vacuum break cylinder should be fully extended, which, in turn, closes the vacuum break valve. If the cylinder retracts when the unit is placed under power, interchange the air lines that power it. (See Figure 5.)
2. If the vacuum break valve does not close completely with the cylinder rod fully extended (for example, as evidenced by clean tank drain-down during an outage) adjust the clevis on the cylinder rod to allow the valve to close.
3. The system pump should be flooded throughout drag chain indexing. Adjust the clean coolant flow valve so that the clean tank refills before the next drum index is called for.

NOTE: The vacuum break section must not drain completely during filter drum indexing or pump starvation or cavitation could occur. If it does, increase coolant flow to the clean tank by opening the clean coolant flow valve as required.

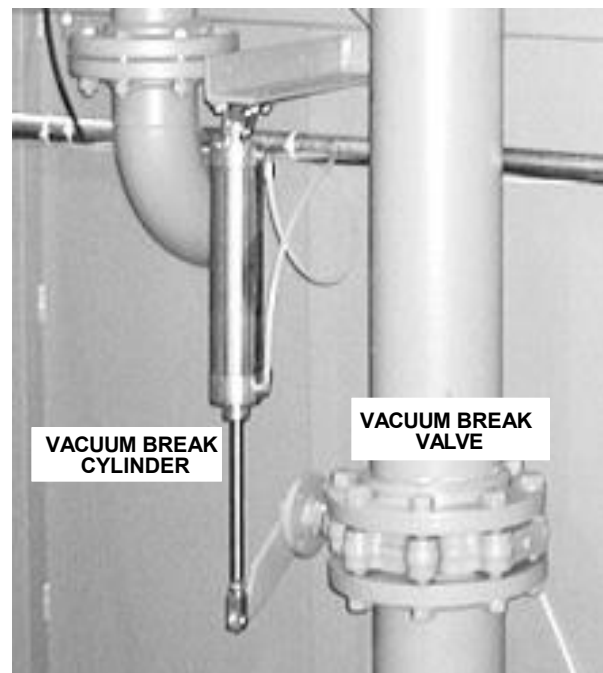

Figure 5. Vacuum Break Valve Adjustment

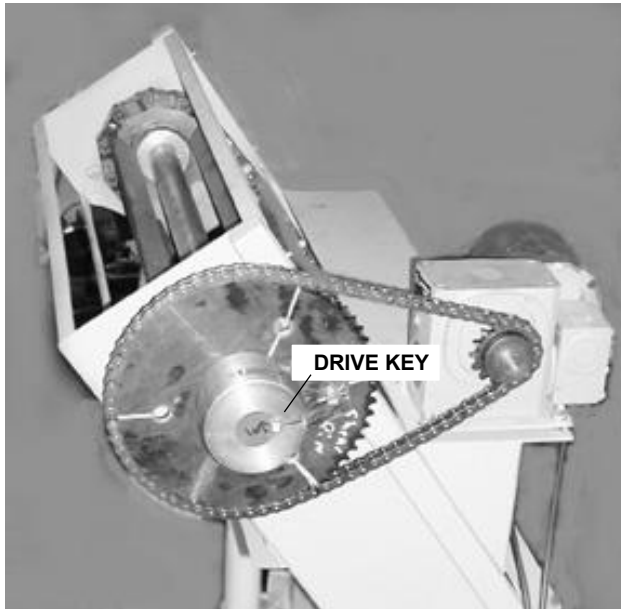

Figure 6. Drive Chain

Service & Maintenance

INSPECTION AND ADJUSTMENT OF HEADSHAFT

WARNING: Failure to follow safety procedures can cause personal injury. Disconnect all electrical power from the filtration unit before removing the headshaft cover or servicing the headshaft assembly.

1. Lock out and tag out electrical power to the filtration unit.
2. Remove the drive system safety cover.
3. Move the drive motor / speed reducer assembly forward on its adjustment screws to relieve tension on the drive chain. See Figure 6.
4. Disconnect the master link from the drive chain and remove the chain from the headshaft drive sprocket.
5. Remove fasteners securing the headshaft cover and remove the cover.
6. The headshaft can now be inspected as follows:
 - A. If the drag chain runs against one side of the conveyor:
 - Loosen the setscrews securing the sprockets to the shaft.
 - Using the proper tools, move the drag chain and sprocket towards the side of the machine having the greatest clearance.
 - Measure the distance between the chain and the side of the machine. Be sure that the distance is equal for both sides.
 - Retighten the headshaft sprocket setscrews.

B. Drive sprocket turns but headshaft does not, check the drive key to ensure that it is not sheared (see Figure 6. If the key is not sheared, see “Replacement of Headshaft Shear Pin:”

C. The headshaft turns, but the drag chain does not move, inspect the headshaft sprocket keyways. If the keyways or square keys are damaged, refer to “Removal of Headshaft” below.

E. The headshaft has lateral movement in the bearings: Check the headshaft-bearing setscrews for tightness. If loose, proceed as follows:

- Adjust headshaft so that the drag chain has equal distance between the chain and the side of the machine.
- Tighten headshaft-bearing setscrews.

F. Headshaft is seized and does not rotate: Refer to “Removal of Headshaft” below.

REPLACEMENT OF HEADSHAFT SHEAR PIN (if provided)

Your headshaft may be equipped with either a shear pin to prevent overload, or with a ratchet slip clutch. The ratchet slip clutch is discussed later in this manual.

WARNING: Failure to follow safety procedures can cause personal injury! Disconnect all electrical power from the filtration unit before removing the headshaft cover or servicing the headshaft assembly.

Refer to Figure 7 and proceed as follows:

1. Lock out and tag out electrical power to the filtration unit.
2. Move the drive motor forward on its adjustment screws to relieve tension on the drive chain.
3. Remove the drive system safety cover.

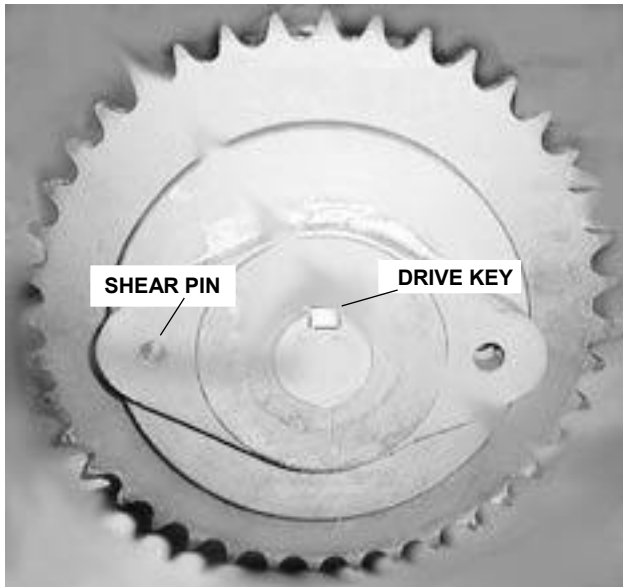

Figure 7. Shear Pin

4. Disconnect the master link from the drive chain, and remove the chain from the headshaft drive sprocket.
5. Remove pieces of the broken shear pin from the driving and driven members of the hub.
6. Align the driving and driven members of the hub, and insert the replacement shear pin.
7. Verify that the replacement shear pin is correctly aligned in the hub.
8. Reinstall the drive chain, and adjust the drive motor chain tension.
9. Reinstall the drive safety cover over the drive system.
10. Apply electrical power to the unit.

RATCHET SLIP CLUTCH (if provided)

This unit is designed to limit the torque transmitted by the drive system when the torque exceeds a preset value as a result of overload, shock load, or jamming of the conveyor. The clutch consists of a driven roller chain sprocket mounted with a set of ratchet-tooth plates on a clutch hub with a back-plate, and a spring with an adjustable hex nut (and locking setscrew) to

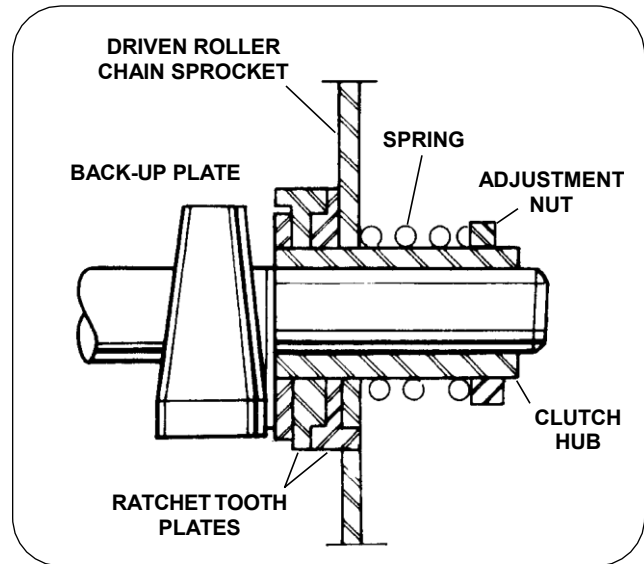

Figure 8. Ratchet Slip Clutch

provide tensioned spring pressure on the sprocket. (See Figure 8.)

When a severe overload occurs the ratchet-tooth plates, engaged on the driven sprocket, push the driven sprocket against the spring and slip on the ratchet-tooth plate until the overload is cleared. After clearing the overload, no resetting is necessary.

Adjustment

This unit is preset at Jorgensen Conveyors, and should only require reset if clearing the overload does not stop the ratcheting. Proceed as follows:

WARNING: Failure to follow safety procedures can cause personal injury! Disconnect all electrical power from the filtration unit before servicing the ratchet slip clutch.

1. Lock out and tag out electrical power to the filtration unit.
2. Remove the drive guards and/or shrouds.
3. Clear the filter conveyor of any jamming material or overload.
4. Load the conveyor with a maximum expected load.
5. Apply electric power and start the conveyor. If the overload continues, lock out and tag out electric power to the conveyor and continue with Step 6.

6. Tighten the adjusting hex nut until the conveyor runs continuously without ratcheting.
7. After final adjustment, lock the hex nut in place with the setscrew.
8. If the conveyor is now functioning properly, replace the guards and/or shrouding, and return the unit to service.

The only maintenance required for the ratchet slip clutch is periodic inspection for rust, corrosion, or binding between the ratchet-tooth plates.

REMOVAL OF THE HEADSHAFT ASSEMBLY

WARNING: Failure to follow safety procedures can cause personal injury! All electrical power must be disconnected from the unit before removing the headshaft cover or servicing the headshaft assembly. Remove air pressure from the unit before removing the headshaft cover or removing the headshaft. Lifting equipment must be employed when disconnecting the drag chain assembly. Lifting equipment must be employed when removing the headshaft assembly.

1. Jog the drag chain until the master link (Figure 9) is at an accessible location.
2. Lock out and tag out electrical power to the filtration unit.
3. Remove the drive system safety cover.
4. Using the adjusting screws, move the drive motor to relieve tension on the drive chain.



Figure 9. Master Link

5. Disconnect the master link from the drive chain, and remove the drive chain from the headshaft drive sprocket.
6. Remove the fasteners securing the headshaft and incline covers. Remove the covers.
7. Locate the master link of the drag chain, and mark the chain where the master link resides.
8. Attach a suitable lifting device to the drag flight chain cleat near the headshaft.
9. Disconnect the drag chain master links (one per side).
10. Using a suitable lifting device, pull the drag chain out of the discharge section of the unit and lower the drag chain between the headsection cross-members.
11. Loosen the setscrews securing the bearings and headshaft sprockets to the headshaft.
12. Attach the lifting device to the headshaft. Place a slight tension on the lifting device.
13. Remove the fasteners securing the headshaft bearings. Remove the non-drive side bearing from the headshaft.
14. Push the headshaft towards the drive side, moving it out of the head section.
15. Once clear of the non-drive side headplate, slide the headshaft sprockets off the headshaft.
16. Continue to move the headshaft out of the head-section. Balance the headshaft, and connect the lifting device to the headshaft outside of the drive side headplate.
17. Slide the headshaft out of the headplate on the drive side and lower the headshaft to a safe working area.

CHANGING DISPOSABLE FILTER MEDIA

Starting a new roll of disposable media is relatively simple:

1. Tie a knot in the beginning of the roll and feed the knot beneath and behind one of the drag chain flights.
2. Continuously press the JOG button on the control panel until the knot in the media exits the unit.

MANUFACTURER	AMBIENT TEMPERATURE	
	15 to 60°F	50 to 125°F
AMOCO	Worm Gear Oil	Cylinder Oil 680
CHEVRON	Cylinder 460X	Cylinder Oil - 680X
EXXON	Cylesstic TK460	Cylesstic TK680
GULF	Senate 460	Senate 680D
MOBIL	600W Super	Extra Hecla Super
SHELL	Valvata Oil J460	Valvata Oil J680
SUN	Gear Oil 7C	Gear Oil 8C
TEXACO	Honor Cyl. Oil	650T Cyl. Oil
UNOCAL	Steaval A	Worm Gear 140
Compound	AGMA 7	AGMA 8

Table 1. Suggested Speed Reducer Lubricants

Drive Center	5"	10"	15"	20"	30"	40"	60"	80"	100"
Horizontal	.25"	.50"	.75"	1.00"	1.50"	2.00"	3.00"	4.00"	5.00"
Vertical	.12"	.25"	.38"	.50"	.75"	1.00"	1.50"	2.00"	2.50"

Table 2. Tangent Length Between Sprockets

3. Be sure that the low media sensor is positioned on the roll.

REDUCER LUBRICATION

Lubrication

Recommended lubrication oil is shown in Table 1. For other temperatures or synthetics contact the manufacturer.

NOTE: When changing oil in a double reduction unit, make sure the primary and secondary chambers are both changed.

DRIVE CHAIN ADJUSTMENT

1. Check sprocket alignment using a straight edge or taut cord stretched across the faces of the reducer drive sprocket and the headshaft sprocket. The tolerance is ± 0.5 degrees or $1/8$ " per foot.

2. Make sure all set screws, bolts and nuts are tight.
3. Check sprockets and components. Make sure all are in good condition and free from contamination. The roller chain should be lubricated and free from chips or turnings.
4. Check chain tension. Deflection of the span (Table 2) for tension purposes should be as follows:
 - Horizontal drive: 4-6% of span length
 - Vertical drive: 2-3% of span length.

DRAG CHAIN ASSEMBLY INSTALLATION AND ADJUSTMENT

Removal

1. Always make sure the conveyor is locked out and tagged out at the power source.
2. Remove the sprocket and chain guards.
3. Remove the drag chain.

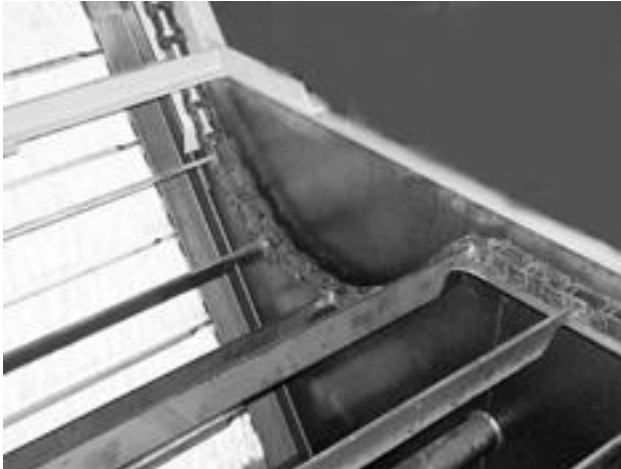

Figure 10. Catenary

4. Remove the cotter pin from both sides of the drag chain assembly (Figure 9), then remove chain pins to disconnect the drag chain assembly.
5. Place the chain pins back in the top half of the drag chain assembly.
6. Facing the discharge opening, extract the lower half of the drag chain. Pull and guide the drag chain assembly to the floor and let it fold. Two people or an overhead lift may be required.
7. Remove all foreign objects from the casing.

8. Inspect the drag chain assembly and casing for worn or damaged parts.

Installation

NOTE: If installing a new drag chain, be sure that the length of the new chain is identical to the length of the old chain so that the catenary will form properly. See Figure 10.

1. Place the end of the drag chain assembly in the lower run of the conveyor casing.
2. Feed the drag chain assembly through the casing until it comes up over the drive sprockets.
3. Pull the top run of the drag chain assembly over the headshaft sprockets until it is centered with the take-up slots.
4. Re-install the chain pins and secure with the cotter pins, making sure all drag chain assembly parts are in their proper position.

LUBRICATION

There are a total of 2 grease fittings that require lubrication – one on either end of the headshaft to lubricate the head shaft bearings. There may be more grease fittings if the unit is equipped with a re-winder or other auxiliary equipment. In any case, grease all bearings as follows.

For normal operating conditions, apply No. 2 grease through the grease fittings every 90 days. Grease should conform to NLGI No. 2 consistency, and should be free of chemical impurities such as free acid or alkali, and mechanical impurities such as dust, rust, metal particles, or abrasives. Add grease slowly until a slight bead forms between the seals.

Troubleshooting

PROBLEM	PROBABLE CAUSE	SOLUTION
Vacuum Break Cylinder		
Cylinder retracts with power off.	Air lines incorrectly connected.	Connect the air lines in the correct manner.
Cylinder acts sluggish or will not move at all.	Air pressure is not between 60 – 80 psi.	Adjust regulated air pressure to 80 psi.
	Flow controls are completely closed.	Flow controls are integral with mufflers installed in exhaust ports of valve. Loosen locknuts on each and rotate screw until each control is wide open. Actuate cylinder and begin closing flow control corresponding to direction of movement. Note that control meters exhaust air. Allow for free cylinder movement with a soft stop. Do not allow cylinder to “slam” into position, which would shorten cylinder life. Retighten the locknut.
System pump starves during drag chain index, or clean tank empties before index is complete.	Vacuum valve does not close completely, allowing the vacuum break section of the clean tank to drain.	Adjust cylinder clevis to achieve full closure of valve.
	Incorrect flow upon re-fill of clean tank.	Adjust ball valve to increase flow into clean tank.
System Pump		
Pump does not pump (starves).	Coolant level is not at correct height.	Add coolant.
	Air leakage in the system.	Check gasketed connections at the vacuum chamber mount flange. Replace gasket and retighten connection.
		Ensure vacuum break valve opens adequately. Readjust as required.
Blinded media.		Jog in new (fresh) media.

WARRANTY

Jorgensen Conveyors, Inc. guarantees the material of our manufacture against defects in material or workmanship under normal and proper use for one year in service or eighteen months from shipment, whichever occurs first. Material which we purchase can be guaranteed by use only to the extent of the original manufacturer's guarantee. We shall not be held liable for damages or delay caused by defective material, or contingent claims of any kind arising from loss of production owing to failure of shipment. Our obligation under this warranty is limited to furnishing new or replacing defective material without charge f.o.b. factory. No allowance will be made for repairs or alterations unless made with our written consent.

Caution should be used in the care and application of our products as the guarantee recited above does not apply where lack of proper maintenance or misapplication exists. We will not be liable for improper storage or handling of our products prior to placement in service.

The within equipment will be specifically designed and manufactured for and will be sold to purchaser for the sole purpose of transporting and conveying raw materials, work in process and finished goods of purchaser. Purchaser does hereby agree to exonerate, indemnify, defend and hold seller harmless of and from all loss, liability and damages which may be suffered by or asserted against the seller, and all costs and expenses which seller may incur because of any claim or claims which may be asserted against seller by any person for death or injury to anyone sustained while riding or attempting to ride upon said equipment.

A word about Jorgensen Conveyors

Founded in 1950, Jorgensen Conveyors has evolved into a leading machine tool conveyor specialist, supplying high-quality, custom designed conveyor and coolant filtration systems to a variety of leading machine tool builders and end user manufacturers in the metal working industry.

A key factor in this growth was the development of our patented chain belt design. None of the parts are welded. Instead, each part, made of extra heavy gauge steel, is held by an axle that passes through the part. If a part should become damaged, the belt assembly is completely detachable so that the part can be replaced quickly. This design also features fewer parts, making it more cost effective.

What really sets Jorgensen apart today is our design capability across the broad range of chip removal applications for CNC (Computer Numerically Controlled) machine tools. Today, Jorgensen Conveyors supplies chip conveyors and coolant filtration systems to machine tool builders and end users in manufacturing sectors such as automotive, heavy equipment, and aerospace, and to contract machine shops that supply parts to these manufacturers.

Jorgensen has also built its reputation in the industry with responsive warranty service. It is a service-oriented philosophy that worked in 1950, works today, and will keep working into the next century.

JORGENSEN CONVEYORS, INC. • 10303 N. Baehr Road • Mequon, Wisconsin 53092-0156
P.O. Box 09156

Phone: 262-242-3089

Fax: 262-242-4382

www.jorgensenconveyors.com

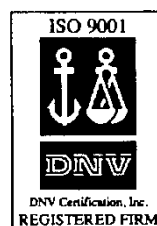

Bulletin No. 01-06 Rev. 0816