

// WEIMA WL(K) 4-8 Series Shredders



The Perfect Shredder Flexibility and High Performance

WEIMA America offers a diverse line of shredding and grinding equipment to the wood, plastic, paper and recycling industries. Our broad range of products include standard machines as well as custom solutions for any size reduction requirements. The WL(K) single-shaft shredders come in different configurations which can handle most materials including, PE, PP, film, sheets, rolls, carpet, wood and much more.

Technical Data

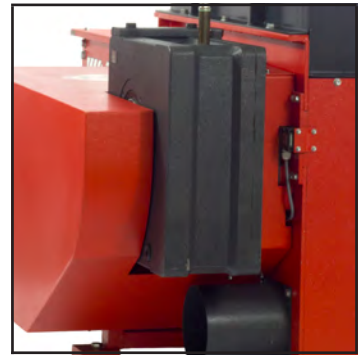
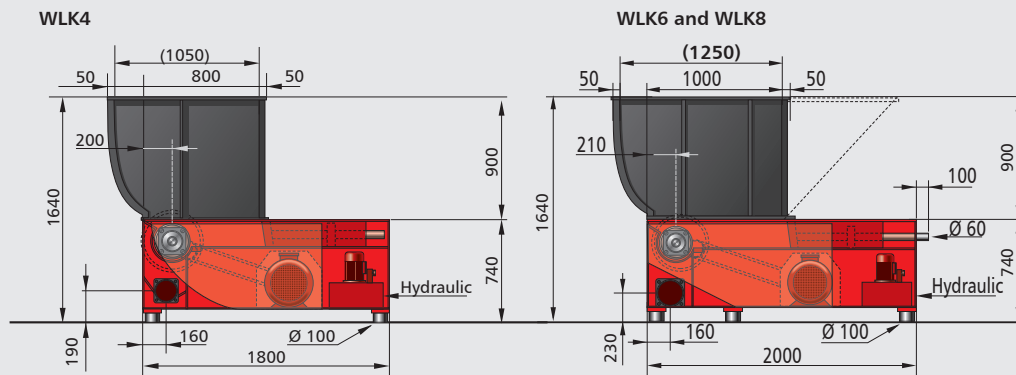

GEARBOX

- WEIMA gearbox design
- Built for shredders
- Limit switch

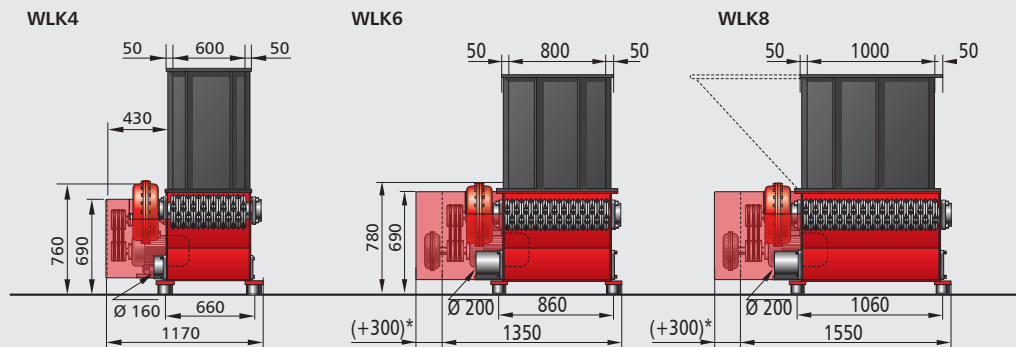

HOPPER AND RAM

- Serrated version optional
- Ram impulse
- Ram comb optional
- Log spacer option

	WL(K) 4	WL(K) 6	WL(K) 8
Hopper opening (Inch):	23.6 x 41.3	31.5 x 49.2	39.4 x 49.2
Hopper vol. (yd³/m³):	0.74 / 0.57	1.17 / 0.9	1.47 / 1.13
Rotor diameter (In./mm):	10 / 252	10 / 252	10 / 252
Rotor speed (rpm):	80 - 120	80 - 120	80 - 120
Power (hp):	30	30	35
(kW):	22	22	27
Rotor knives:	1.57 x 1.57 (40 x 40)	1.57 x 1.57 (40 x 40)	1.57 x 1.57 (40 x 40)
Number of knives:	14/28	21/42	27/54
Screen size (In./mm):	Screen size varies depending on application and throughput requirements.		
Connection-Ø (In./mm):	6 / 160	8 / 200	8 / 200



CONTROL PANEL

- PLC control for efficient size reduction

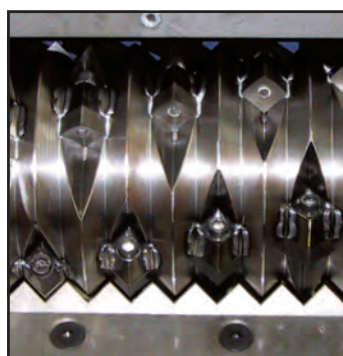

ROTOR

- Minimum wear of knives
- Double row of knives

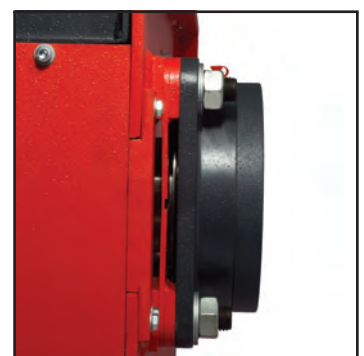

BEARINGS*

- Bearings with spatter ring
- Flange mounted
- Pillow block available

WEIMA America, Inc.

3678 Centre Circle, Fort Mill, SC 29715

Phone: 803-802-7170 // Fax: 803-802-7098

www.weimaamerica.com // info@weimaamerica.com

The throughput rate depends on material and screen size.

Special configurations are available. Call for details.

Demonstrations and tests with your materials are possible in our facility by appointment.