

Following is the survey information Jorgensen will require to properly size and quote a ChipBlocker® kit for your chip conveyor. Simply record your company information, the required dimensions from your conveyor per the drawing below, and then fax this page to the Jorgensen address below and we will submit a sales quotation to you:

Company Name: \_\_\_\_\_  
 Address: \_\_\_\_\_  
 City: \_\_\_\_\_ State: \_\_\_\_\_ Zip Code: \_\_\_\_\_  
 Phone: \_\_\_\_\_ Fax: \_\_\_\_\_  
 Email: \_\_\_\_\_  
 Contact Name: \_\_\_\_\_ Title: \_\_\_\_\_  
 Fax To: Jorgensen Conveyors, Inc. 10303 N. Baehr Rd. Mequon, WI Attn: Sales Dept Fax No: 262-242-4382  
 Conveyor Manufacturer \_\_\_\_\_  
 If your conveyor is a Jorgensen product, please supply the serial number \_\_\_\_\_  
 Machine Tool Brand/Model \_\_\_\_\_

### ChipBlocker® Critical Dimensions Layout

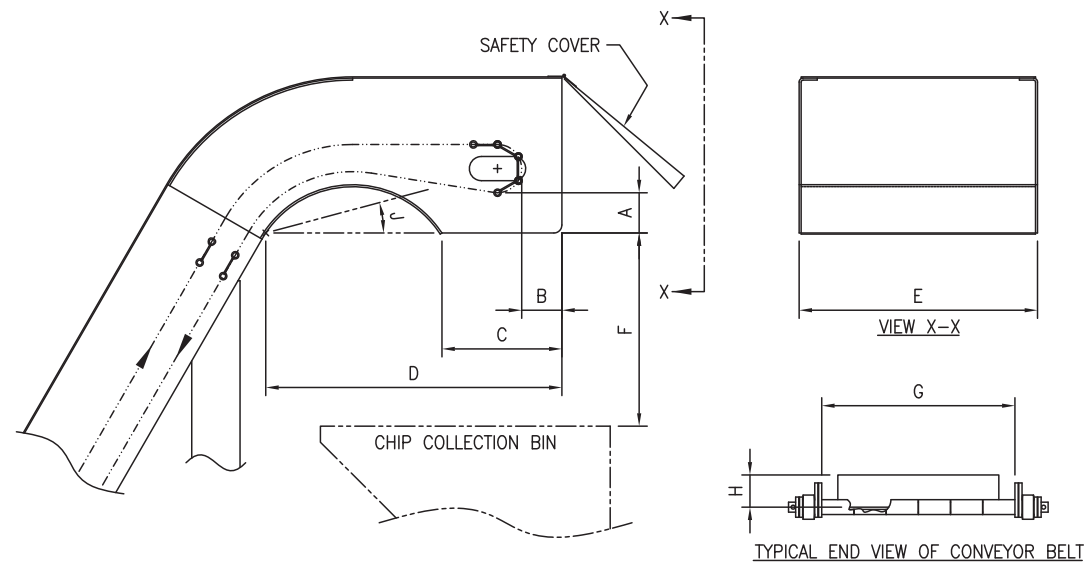

	DESCRIPTION	DIM'S.
A	DISTANCE BETWEEN BELT FLAT & BOTTOM EDGE OF DISCHARGE	
B	DISTANCE BETWEEN BELT FLAT & OUTSIDE EDGE OF DISCHARGE (WITHOUT SAFETY COVER)	
C	HORIZONTAL LENGTH OF DISCHARGE OPEN AREA (WITHOUT SAFETY COVER)	
D	POINT OF CONTACT BETWEEN BOTTOM OF DISCHARGE & UNDERSIDE OF CASING/FRAME	
E	OUTSIDE WIDTH OF CASING/FRAME AT END OF DISCHARGE	
F	DISTANCE BETWEEN BOTTOM OF DISCHARGE & CHIP COLLECTION BIN	
G	WIDTH OF CONVEYOR BELT CARRYING SURFACE (INSIDE CHAIN COMPONENTS)	
H	HEIGHT OF CONVEYOR BELT MATERIAL CARRYING CLEAT	
J	ANGLE OF DISCHARGE (IF APPLICABLE) – THIS DIM. IN SAMPLE VIEW ABOVE IS 0°	



10303 North Baehr Road  
 Mequon, Wisconsin 53092  
 1-800-325-7705  
 www.jorgensenconveyors.com

ChipBlocker® Availability for Various Types of Conveyor Configurations			
NOT AVAIL.	NOT AVAIL.	AVAILABLE	AVAILABLE
Type 1	Type 2	Type 3	Type 4

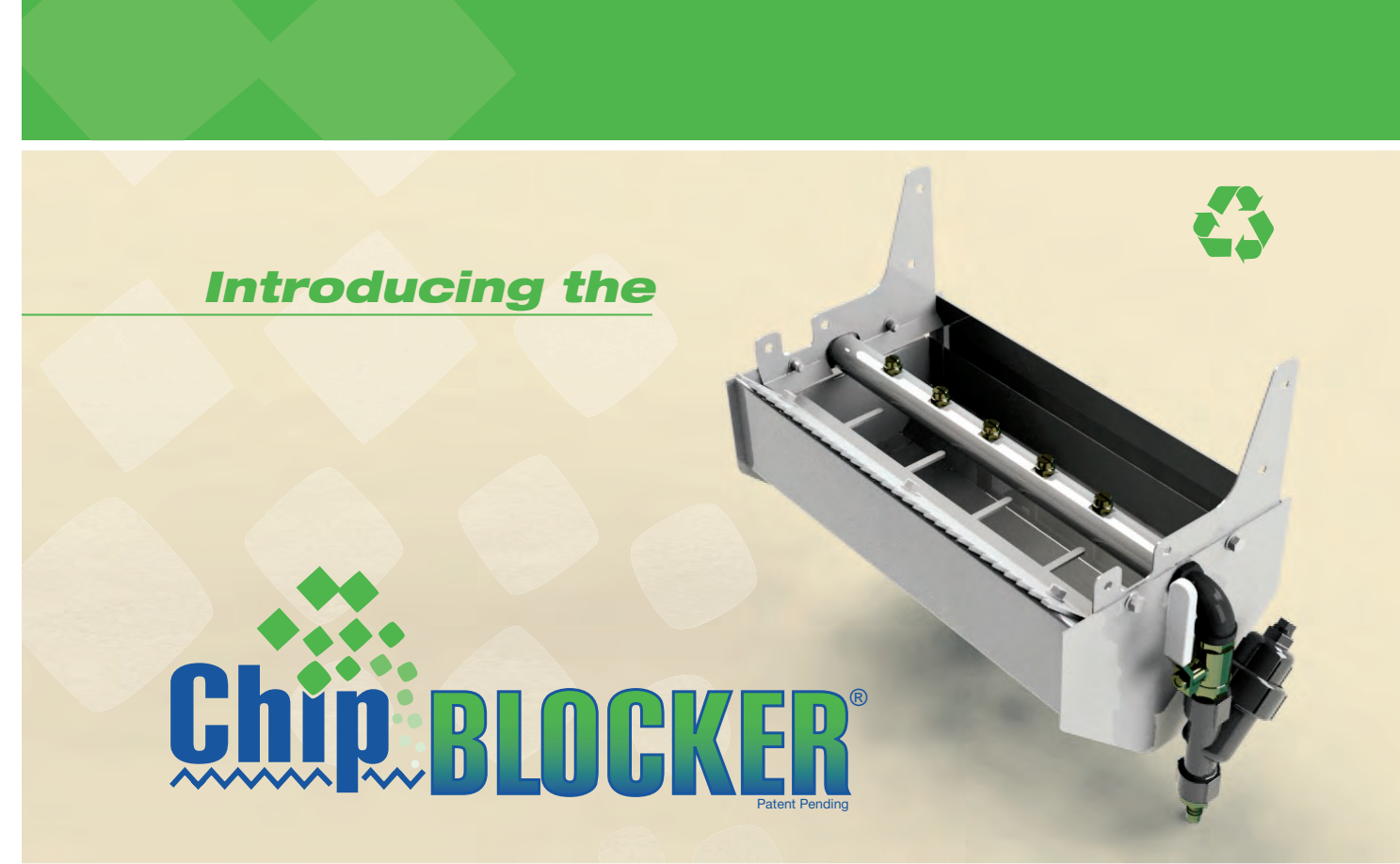

**“A simple, retrofitable accessory unit for your metal cutting machine tool chip conveyor. Virtually eliminates chip carry-back into the conveyor and chip accumulation in the coolant supply tank.”**

Minimizes chip carry back into the conveyor in a metal cutting machine tool application!  
 Provides the following benefits:

- ◆ Less machine downtime and labor to clean out migrated chips accumulated in machine coolant tank
- ◆ Less chip carryback into the conveyor resulting in fewer conveyor jams
- ◆ Cleaner coolant means less clogging of coolant supply lines, nozzles and tank screens
- ◆ Minimize disrupted coolant supply to cutting area from clogged coolant lines – results in reduced cutting tool damage and fewer rejected parts
- ◆ Cleaner coolant means better machined part finish
- ◆ Helps ensure good coolant flow and pressure for bed flushing pumps so chips don't accumulate inside the machine
- ◆ Extends useful life of coolant
- ◆ Extended conveyor and coolant pump life due to less wear from chip migration
- ◆ More cost effective solution than the use of air knife chip blow-off systems and the associated on-going cost of compressed air in the shop (several thousand dollars per year!)
- ◆ The ChipBlocker® is an environmentally friendly “green” manufacturing product requiring no additional consumable energy or materials.
- ◆ Uses existing coolant from sump and existing machine supply pump
- ◆ Reduces coolant carryout
- ◆ May eliminate the need for more expensive coolant filtration systems



10303 North Baehr Road • Mequon, Wisconsin 53092  
 1-800-325-7705 • www.jorgensenconveyors.com



## Typical ChipBlocker® Installation

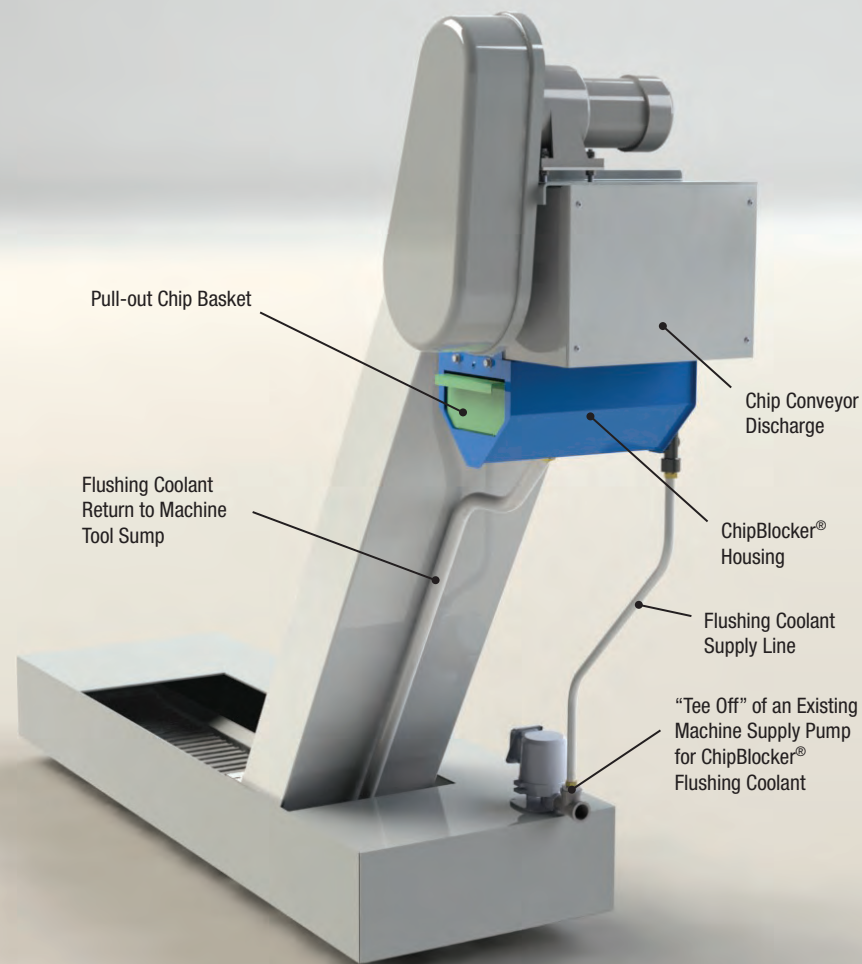

## Detailed View of ChipBlocker® Housing

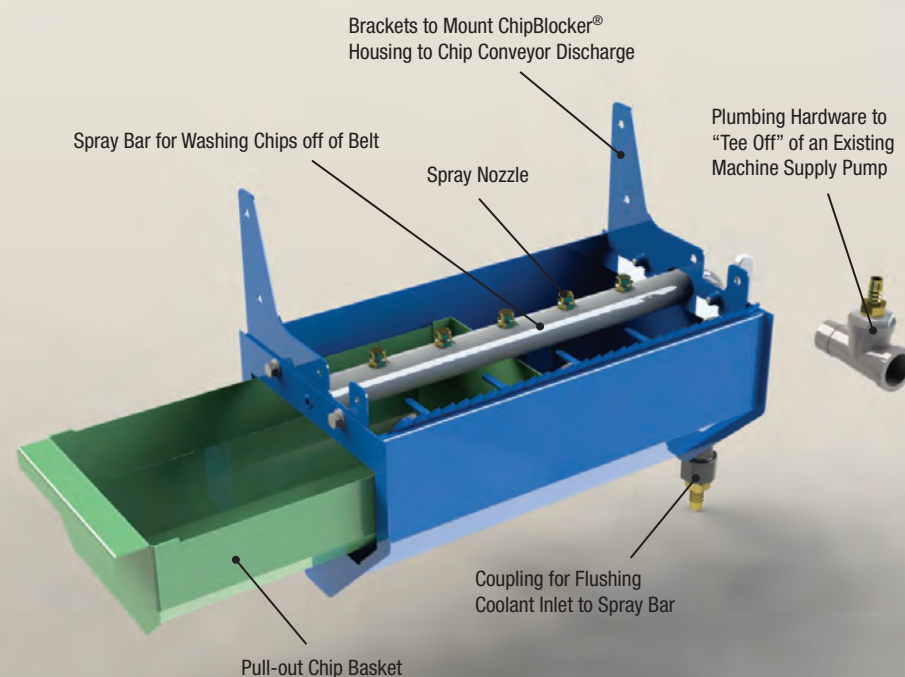

## How it works:

The ChipBlocker® is a compact unit which is mounted to the discharge end of a hinged steel belt chip conveyor. It can be installed on a newly purchased conveyor, but also can be retro-fitted to most existing chip conveyors as well!

An existing machine tool coolant pump is used as the source of coolant which the ChipBlocker® unit will use to flush chips off the underside of the conveyor belt after the chip discharge point, but before the belt returns to the inside of the conveyor housing. Jorgensen supplies a standard "Street Tee" fitting with the ChipBlocker® kit to "tee off" of an existing machine tool coolant supply pump. Typically, only about 1.5 gallons per minute of coolant flow is all that is required for proper performance of the ChipBlocker® unit.

Clean coolant is pumped up to the spray bar header in the ChipBlocker® via the coolant supply line (supplied as part of the ChipBlocker® kit). A series of spray nozzles positioned across the spray bar header gently wash the chips off the belt.

Washed-off chips and fines fall into a pull-out chip basket and the coolant drains through the screen into a return line hose (supplied as part of the ChipBlocker® kit) and back to the machine tool coolant tank.

The conveyor belt returns into the conveyor housing free of any chips, thus eliminating the opportunity for any significant migration of chips into the machine tool coolant supply tank.

The chip basket is removable and easily accessible. Periodically, the operator would remove the basket by hand and dump out the accumulated chips.



## Items included in the Jorgensen ChipBlocker® installation kit:

- ◆ ChipBlocker® housing
- ◆ Flexible Coolant supply hose
- ◆ Flexible Coolant return hose
- ◆ 1" NPT x .5" NPT Street Tee fitting
- ◆ Strainer filter for supply coolant
- ◆ Hose clamps for both hoses
- ◆ Miscellaneous plumbing supplies
- ◆ Fastener set for mounting ChipBlocker® unit to conveyor

## Installation of the ChipBlocker® is simple:

1. Properly locate the mounting point for the ChipBlocker® housing on the discharge end of your conveyor (detailed instructions will be provided with the kit).
2. Use the ChipBlocker® mounting bracket holes to mark and drill the mounting holes in the conveyor side plates.
3. Use the mounting bolts provided in the kit to mount the ChipBlocker® housing to your conveyor.
4. Connect your coolant return line hose to the bottom fitting of the ChipBlocker® and route the drain hose to your coolant tank.
5. Determine the existing coolant supply pump you will use for the coolant source and install the tee fitting to the pump outlet. Attach your clean coolant supply line hose to the supply pump tee and the coupling inlet to the spray bar at the ChipBlocker® housing.
6. Adjust the ball valve controlling the coolant flow to your cleaning nozzles so that the spray pattern has an overlapping spray. A gentle wash contact to the belt will be all that is necessary for effective belt cleaning. Typically about 1.5 gpm is all that is required.
7. The installation of the complete ChipBlocker® kit typically takes less than two hours!



10303 North Baehr Road • Mequon, Wisconsin 53092  
1-800-325-7705 • [www.jorgensenconveyors.com](http://www.jorgensenconveyors.com)