

Filterveyor®

By Jorgensen Conveyors, Inc.



**Permanent Media Gravity
Drum Filtration System**

Filterveyor®

By Jorgensen Conveyors, Inc.

Applications

The Filterveyor® permanent media gravity drum filtration system effectively combines chip removal and coolant filtration. The system efficiently removes a wide range of chips and small fines of steel, aluminum, brass and many other materials, to 50 microns nominal.

Coolant Flow Rate

Model	Requirements for Machine*	
	Gallons Per Minute	Litres Per Minute
FV - 600	0 — 60 gpm	0 — 227 lpm
FV - 900	61 — 90 gpm	231 — 341 lpm
FV - 1200	91— 120 gpm	344 — 454 lpm

* Flow rates to 1000 gpm, (3785 lpm) available.



Single Stage Filterveyor®



Dual Stage Filterveyor®

Features and Benefits

- ▼ Single stage design for broken/fine chips and swarf sludge.
- ▼ Dual stage design for bushy, stringy and high chip load applications.
- ▼ Self cleaning drum system for maintenance free operation.
- ▼ Minimal sump maintenance allows for extended coolant life and less downtime.
- ▼ No disposable media.
- ▼ Very efficient in difficult machining applications where many fine chips are present.
- ▼ Dual drives for increased system reliability.
- ▼ Capable of providing filtration to multiple machines.

- ▼ Low profile designs available for machine fit up.
- ▼ Less reliance on downstream bag or cartridge filters than conventional conveyor systems.
- ▼ Drop-in designs for existing coolant tanks.
- ▼ Extends tooling life and improves machining accuracy.

System Options

- ▼ High pressure coolant system
- ▼ Pumps/plumbing/coolant transfer
- ▼ Downstream filtration
- ▼ Tramp oil skimmers
- ▼ Coolant chillers/heat exchangers
- ▼ Complete electrics/controls
- ▼ Air knife

Permanent Media Gravity Drum Filtration System

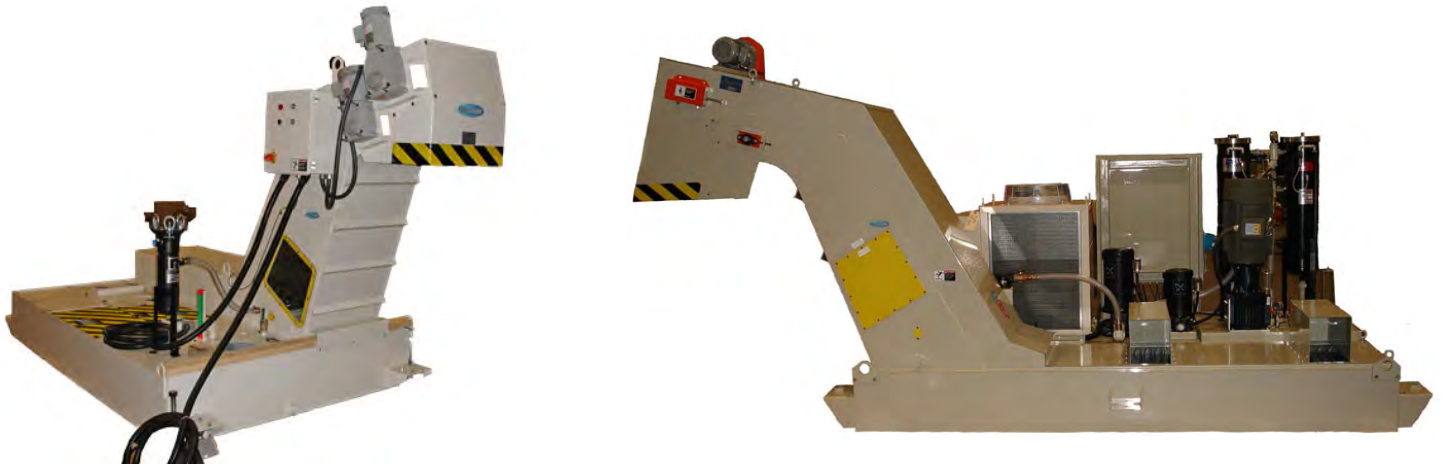

Filterveyor® Application Chart

Material Type*	Steel		Cast Iron		Aluminum		Brass	
	Single	Dual	Single	Dual	Single	Dual	Single	Dual
Chip Type								
Bushy & Tight <i>(Birds Nest)</i>	▼	▼	—	—	▼	▼	▼	▼
Bushy & Loose	▼	▼	—	—	▼	▼	▼	▼
Broken Chips <i>(6's & 9's)</i>	▼	▼	▼	▼	▼	▼	▼	▼
Fine Chips <i>(Free Flow Granular)</i>	▼	▼	▼	▼	▼	▼	▼	▼
Swarf Sludge	▼	▼	▼	▼	▼	▼	▼	▼

▼ Recommended Application
 ▼ Used In Some Applications
 ▼ Not Recommended

* For other materials please contact a Jorgensen proposal engineer.



Established supplier relationships –

Jorgensen has established long standing relationships with many key suppliers. New suppliers of raw materials and components evolve from a rigorous qualification and selection process. Requirements include product quality, company reliability, competitive pricing and on-schedule delivery.

What Customers are Saying

“ Jorgensen has always been there with new ideas when we needed them. We are happy with their support and with the quick turn-around they give us on quotes. We are very happy with the product's reliability and with their support.”

*Himat Patel
Hurco Manufacturing*

Filterveyor®

By Jorgensen Conveyors, Inc.

Single Stage Filterveyor®

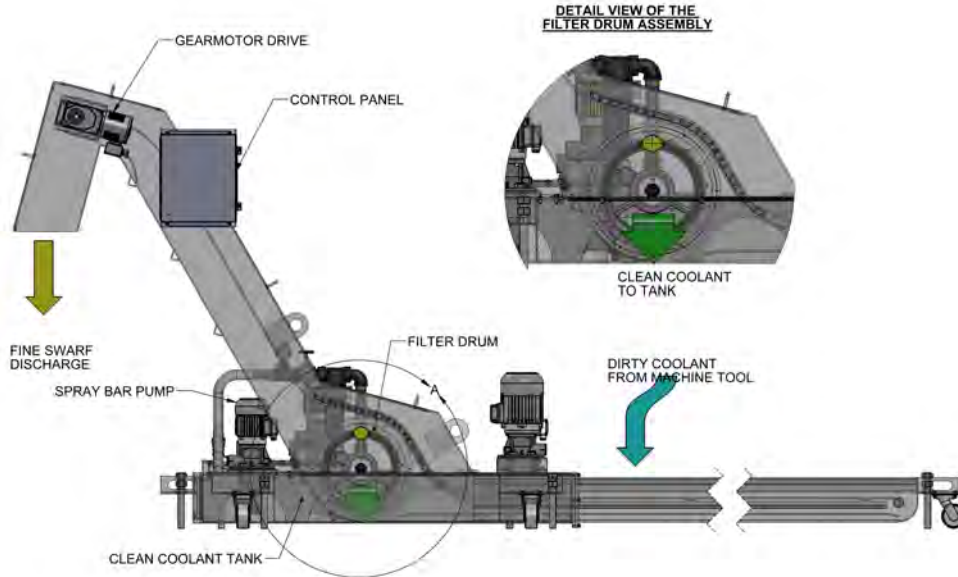

Dual Stage Filterveyor®

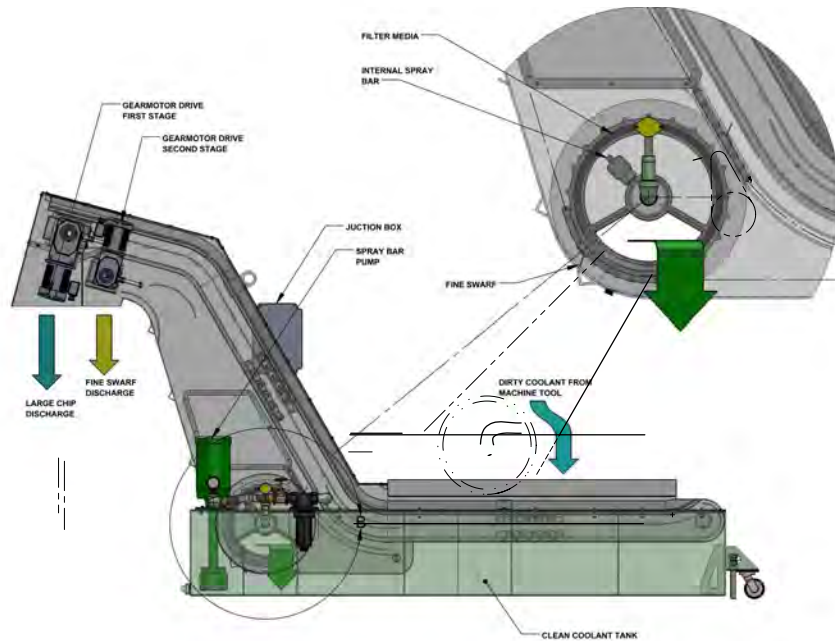

Main Office and Manufacturing
10303 North Baehr Road
Mequon, WI 53092

Toll-Free: 1.800.325.7705

Website: www.jorgensenconveyors.com
E-mail: info@jorgensenconveyors.com

