

OPERATOR MANUAL

Magnetic Conveyor



WARNINGS

- THIS CONVEYOR IS DESIGNED FOR A SPECIFIC APPLICATION.
- CHECK FRAME AND CHAIN FOR DAMAGE DURING SHIPMENT.
- READ THE MANUAL FOR PROPER INSTALLATION AND START-UP.
- CONVEYOR MUST BE LEVEL AND PLUMB FOR PROPER OPERATION.
- CHECK ALL DRIVE COMPONENTS FOR ALIGNMENT AND TENSION.
- CONTROL BOXES AND OTHER ATTACHMENTS MUST BE MOUNTED WITH EXTREME CARE SO AS NOT TO INTERFERE WITH CONVEYOR OPERATION
- VERIFY ALL WIRING FOR CORRECT VOLTAGE, CYCLE & AMPERAGE
- PROPER CHAIN TENSIONING IS REQUIRED AT INSTALLATION, AND WHEN IN USE FOR 30-45 DAYS, A READJUSTMENT SHOULD BE PERFORMED.
- LOCK OUT AND TAG OUT POWER SOURCE PRIOR TO ANY ADJUSTMENTS OR MAINTENANCE.
- KEEP HANDS AWAY FROM CONVEYOR WHEN POWER SOURCE IS NOT LOCKED OUT.
- DO NOT STEP ON CONVEYOR.

DANGER

Use OSHA Lockout/Tagout procedures before performing any inspections, adjustments, or maintenance procedures on this equipment. Failure to follow OSHA required procedures at all times without exception could result in severe injury and is against Federal workplace safety laws.

Table of Contents

DESCRIPTION.....	1
General.....	1
Conveyor Casing Construction.....	1
Conveyor Medium	1
Drive	1
Conveyor Tail End.....	1
Overload Devices.....	1
Current Limiter	1
Ratcheting Slip Clutch (if provided — indirect drive only)	2
Shear Pin (if provided — indirect drive only).....	2
INSTALLATION	2
START UP INSTRUCTIONS.....	3
SERVICE AND MAINTENANCE.....	3
Speed Reducer and Motor.....	3
Indirect Drive Reducer Lubrication.....	3
Drive Chain Adjustments.....	3
Current Limiter	3
Ratcheting Slip Clutch (if provided — indirect drive only)	4
LUBRICATION	4
Grease Lubrication.....	4
Oil Lubrication.....	5
TROUBLESHOOTING.....	6

IMPORTANT

- 1. Refer to *WARNINGS* on the inside front cover.**
- 2. Review the *Lubrication Section* of this manual.**
- 3. Variations in design of this conveyor may not be covered in this manual. Call Jorgensen Conveyors if additional information is required.**
- 4. Never batch load this conveyor.**
- 5. Be sure the conveyor is turned on and operating satisfactorily before loading the conveyor.**

A word about Jorgensen Conveyors

Founded in 1950, Jorgensen Conveyors has evolved into a leading machine tool conveyor specialist, supplying high-quality, custom designed conveyor and coolant filtration systems to a variety of leading machine tool builders and end user manufacturers in the metal working industry.

A key factor in this growth was the development of our patented chain belt design. None of the parts are welded. Instead, each part, made of extra heavy gauge steel, is held by an axle that passes through the part. If a part should become damaged, the belt assembly is completely detachable so that the part can be replaced quickly. This design also features fewer parts, making it more cost effective.

What really sets Jorgensen apart today is our design capability across the broad range of chip removal applications for CNC (Computer Numerically Controlled) machine tools. Today, Jorgensen Conveyors supplies swarf and part conveyors and coolant filtration systems to machine tool builders and end users in manufacturing sectors such as automotive, heavy equipment, and aerospace, and to contract machine shops that supply parts to these manufacturers.

Jorgensen has also built its reputation in the industry with responsive service. It is a service-oriented philosophy that worked in 1950, works today, and will keep working into the next century.

DESCRIPTION

General

This manual discusses the Jorgensen Magnetic Conveyor.

The magnetic conveyor is a conveyor process used to collect small pieces of iron material or parts, transporting these items to a collecting container (refer to Figure 1). The materials are dropped on the top of the conveyor housing (referred to as the “slide plate”), which is made of non-magnetic stainless steel. Permanent magnets on a chain conveyor system below the slide plate attract the iron materials and particles, carrying them along the slide plate, up the incline, to the discharge.

Conveyor Casing Construction

The conveyor casing is a welded, watertight unit fabricated from sheet metal sections. Tracks are welded onto the inside of the casing sidewalls. The tracks act as supports and guides for the conveyor chain assembly. (See Figure 2)

Conveyor Medium

The magnetic conveyor medium consists of ceramic magnets (Figure 2) encased in stainless steel, suspended between double-strand roller chains circulating under a stationary non-magnetic stainless steel slide plate. The magnets have infinite life and are submerged in oil. The casing is sealed and there are no external moving parts to cause jamming. The oil bath provides continuous lubrication for long chain life.

Drive

The magnetic conveyor headshaft is driven by an electric motor through a speed reducer. The output of the speed reducer is connected directly to the headshaft so that torque is transmitted via the headshaft and twin sprockets to the conveyor chain. Alternative options include the headshaft driven through a chain between the speed reducer and driven sprocket. This drive arrangement can be comprised of a gearmotor, or a reducer and a motor.

Conveyor Tail End

The tail end of the magnetic conveyor is equipped with twin chain sprockets on self-lubricating bushings (Figure 2). The shaft on which the sprockets ride is mounted on a spring-loaded take-up assembly, which maintains tension on the carrying chains. This tension is preset at the factory and does not typically require adjustment.

Overload Devices

These conveyors are equipped with either of three devices to prevent damage or injury due to overloading: 1) a current limiter, 2) a ratcheting slip clutch, or 3) a headshaft shear pin. Each is discussed below.

Current Limiter

The current limiter is a safety device used to protect the conveyor in the unlikely event of a jam or overload. This device is an electronic alternative to the mechanical ratchet clutch and other mechanical devices.

Magnetic Conveyor

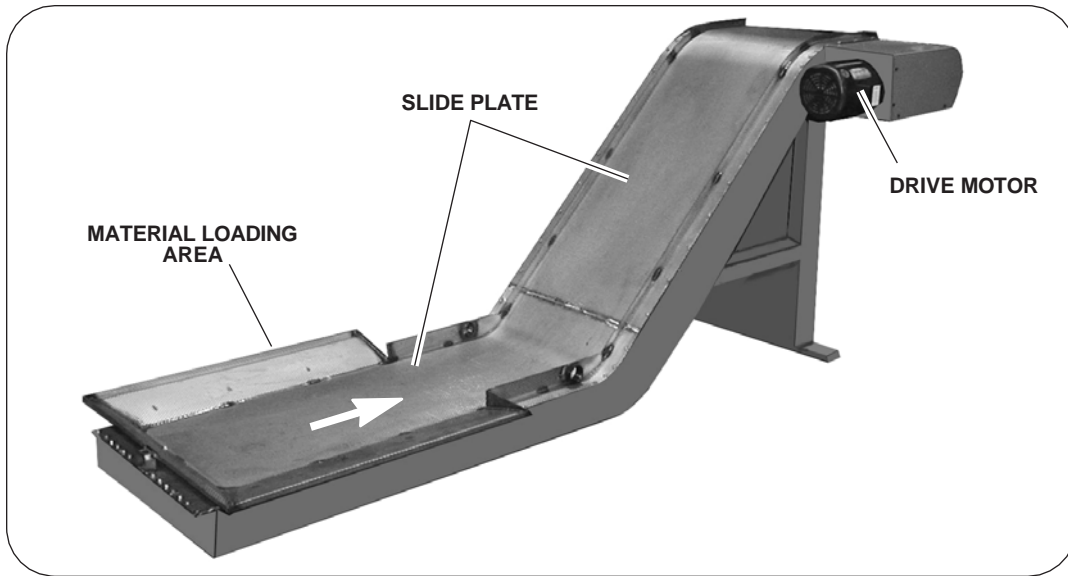

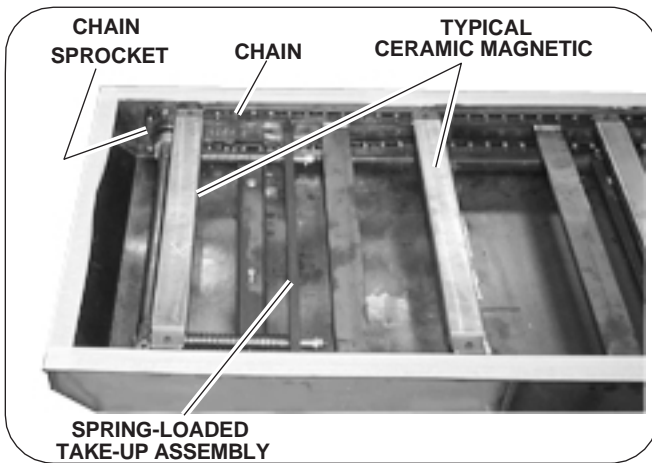

Figure 2. Conveyor Tail End

The current limiter senses motor current and, within milli-seconds, shuts down the conveyor if the current rises above a preset level. Contacts can also be provided for an audible or visual alarm when shutdown occurs.)

Depending on user preference, the current limiter option can be purchased in two different configurations:

1. Mounted in a separate electrical box along with a set of contactors.
2. Mounted in a control ordered with the conveyor and supplied by Jorgensen Conveyors.

Functionally, both configurations operate in the identical manner. The current limiter is always used on the direct drive system, but it can also be used on the indirect drive system; the current limiter replaces the shear pin or ratcheting slip clutch, although the driven sprocket is still used.

Ratcheting Slip Clutch (if provided – indirect drive only)

This unit is designed to limit the torque transmitted by the drive system as a result of overload, shock load, or jamming of the conveyor. The clutch includes an adjustable tension spring that provides pressure on a pair of ratchet-tooth plates.

When a severe overload occurs, the ratchet-tooth plates, fastened to the driven sprocket, push the driven sprocket against the spring and slip on the ratchet-tooth plate until the overload is cleared. After clearing the overload, resetting is not necessary. The ratcheting slip clutch is shown in Figure 3.

Shear Pin (if provided – indirect drive only)

The headshaft may be equipped with a shear pin in the driven sprocket to prevent overload. When an overload occurs, the pin shears to remove the load from the motor and speed reducer. The shear pin must then be replaced, as explained under “Headshaft Shear Pin Replacement.”

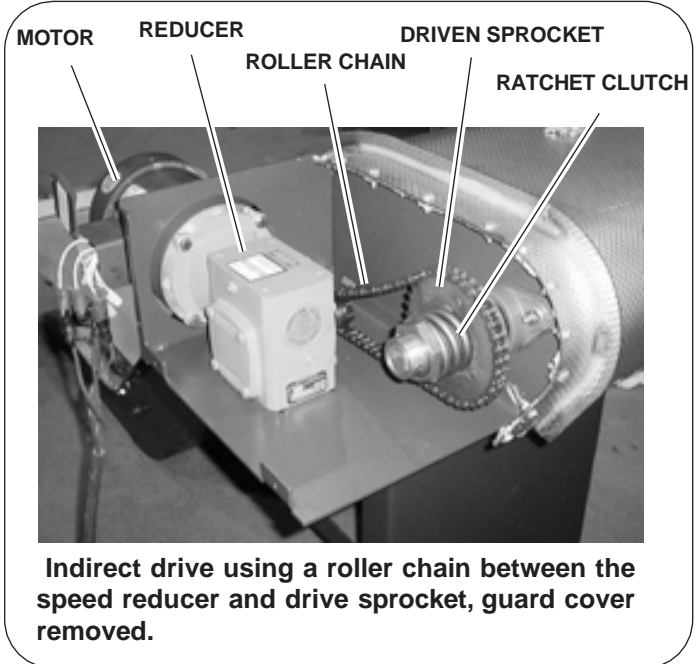

Indirect drive using a roller chain between the speed reducer and drive sprocket, guard cover removed.

Figure 3. Indirect Drive System

INSTALLATION

The conveyor unit is shipped fully assembled. As a safety precaution, be sure to use the proper lifting device to unload the unit.

Uncrate the unit carefully, and inspect for damage that may have occurred during transit. If damage has occurred, notify the carrier immediately. Review this manual in its entirety before beginning installation. If you have any questions, call Jorgensen Conveyors immediately.

This unit has been lubricated, run-in, and tested in Jorgensen’s facility. However, transportation can affect factory settings.

- A final assembly drawing, specific to your conveyor unit, has been provided. Refer to this drawing and use the following discussion as a guide on how to proceed with installation.
- Move the unit into position.

- Place blocking and shimming under the full width of the load section of the unit to distribute weight uniformly. Be sure that the unit is level side-to-side (end-to-end is not important) and that the unit interfaces correctly with the machine.

NOTE: Some units are equipped with adjustable casters to allow movement of the unit. Others are equipped with adjustable articulated leveling bolts.

- Connect all piping and couplings, and verify that all fittings are tight.
- Refer to the electrical schematic (shipped with the unit if applicable) and connect electric power according to the schematic. A suggested schematic diagram for connecting the conveyor into the machine tool circuit can be provided, if applicable.

START UP INSTRUCTIONS

Initially (and after prolonged shutdown) be sure that the conveyor drive has been correctly wired and that all covers and shrouds are in place.

Operate the conveyor for approximately 15 minutes to observe and confirm trouble-free operation before placing the unit in service. (The unit is usually operated through pushbuttons located on the machine, although, when requested, the controls can be mounted on the conveyor.)

If the conveyor has been shut down for a prolonged period, proceed as follows:

- Verify that all bolts in the take-up assembly and drive unit are tight.
- Be sure that the roller chain on an indirect drive unit has been properly lubricated (brushed with light-weight oil).
- If an unsealed indirect drive speed reducer is used, be sure that the speed reducer is correctly lubricated, as described later in this manual under "LUBRICATION."

SERVICE AND MAINTENANCE

The conveyor requires minimal maintenance except for lubrication of the drive system in order to sustain trouble-free operation.

Speed Reducer and Motor

Direct Drive Units. The speed reducer is mounted directly to the headshaft. The speed reducer is lubricated and sealed by the manufacturer and does not require further lubrication. The motor bearings are also sealed and do not require further lubrication.

Indirect Drive Units. Optionally, conveyors may be equipped with a roller chain in conjunction with a speed reducer. These may require periodic lubrication, and the roller chain may require occasional adjustment.

Indirect Drive Reducer Lubrication. The speed reducer used in the indirect drive system may require periodic lubrication. (Check the instructions affixed to the reducer.) Recommended lubrication oil is shown later under "LUBRICATION" in Table 2. For unusual temperatures, or to use synthetic oils, contact the manufacturer.

Drive Chain Adjustments

Proceed as follows:

1. Check sprocket alignment using a straight edge or taut cord stretched across the faces of the drive sprocket and the driven sprocket (Figure 4). The tolerance is ± 0.5 degrees or 3.5 mm per 0.3 m (1/8" per foot).
2. Check sprockets and components. Be sure that all are in good condition and free from contamination. The roller chain should be lubricated and free from chips or turnings.
3. Check roller chain tension. Deflection of the span shown is in Figure 4 and Table 1.
4. Be sure all setscrews, bolts, and nuts are tight.
5. Lubricate the roller chain by brushing with light-weight oil.

Current Limiter

The current limiter can best be adjusted with the conveyor operating under typical load:

1. With the conveyor running, gradually turn the adjustment knob on the limiter counter-clockwise until the limiter trips out and stops the conveyor.
2. After the conveyor has stopped, adjust the setting a small amount higher and restart the conveyor. If the conveyor runs without being shut down by the current limiter, you are ready to begin normal operation.

Table 1. Deflection of Roller Chain Between Sprockets

Drive Center	5"	10"	15"	20"	30"	40"	60"	80"	100"
Horizontal	.25"	.50"	.75"	1.00"	1.50"	2.00"	3.00"	4.00"	5.00"
Vertical	.12"	.25"	.38"	.50"	.75"	1.00"	1.50"	2.00"	2.50"

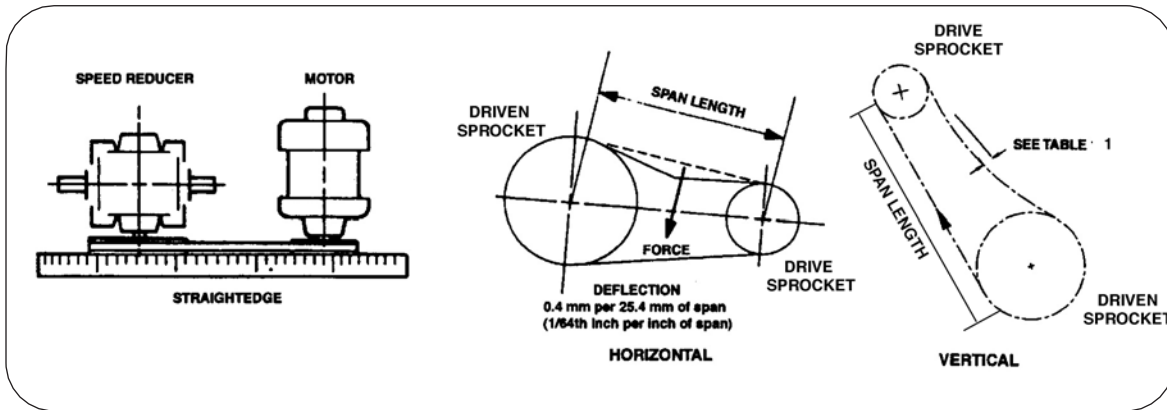

Figure 4. Reducer / Motor Alignment and Tension Adjustment

If the limiter still trips, repeat the above procedure until the conveyor runs continuously without tripping out. This setting will be a good starting point; through experience with the specific load and load procedures, you may want to adjust the limiter accordingly.

Ratcheting Slip Clutch (if provided – indirect drive only)

This unit is preset at Jorgensen Conveyors, and should only require resetting if clearing the overload does not stop the ratcheting. Refer to Figure 5 and proceed as follows:

1. Clear the conveyor of any jamming material or overload.
2. Load the conveyor with the maximum expected load.

WARNING Failure to follow safety procedures can cause personal injury! Disconnect all electrical power from the conveyor unit before servicing the ratchet slip clutch.

3. Lock out and tag out electrical power to the conveyor unit.
4. Remove all drive guards and/or covers.
5. Loosen the setscrew on the clutch-adjusting nut. Tighten the adjusting nut 1/4 turn.

NOTE: The ratchet slip clutch is preset at Jorgensen Conveyors to 1-5/8"

(41.3 mm) (A, Figure 5). Do not compress the spring to anything less than 1-1/2" (38.1 mm) because this would disable the clutch.

6. Apply electric power, restart the conveyor, and observe operation of the clutch. If the overload (ratcheting) continues, lock out and tag out electric power to the conveyor and continue with Step 7.
7. Repeat steps 5 and 6 until the conveyor runs continuously without ratcheting.
8. After final adjustment, lock the adjusting nut in place with the setscrew.
9. If the conveyor is now functioning properly, replace the guards and covers, and return the unit to service.
10. The only maintenance required for the ratchet slip clutch is periodic inspection for wear, rust, corrosion, or binding between the ratchet-tooth plates.

LUBRICATION

Grease Lubrication

There are a total of 2 grease fittings that require lubrication – one on either end of the headshaft to lubricate the headshaft bearings. Grease all bearings as follows.

For normal operating conditions, apply No. 2 grease through the grease fittings every 90 days.

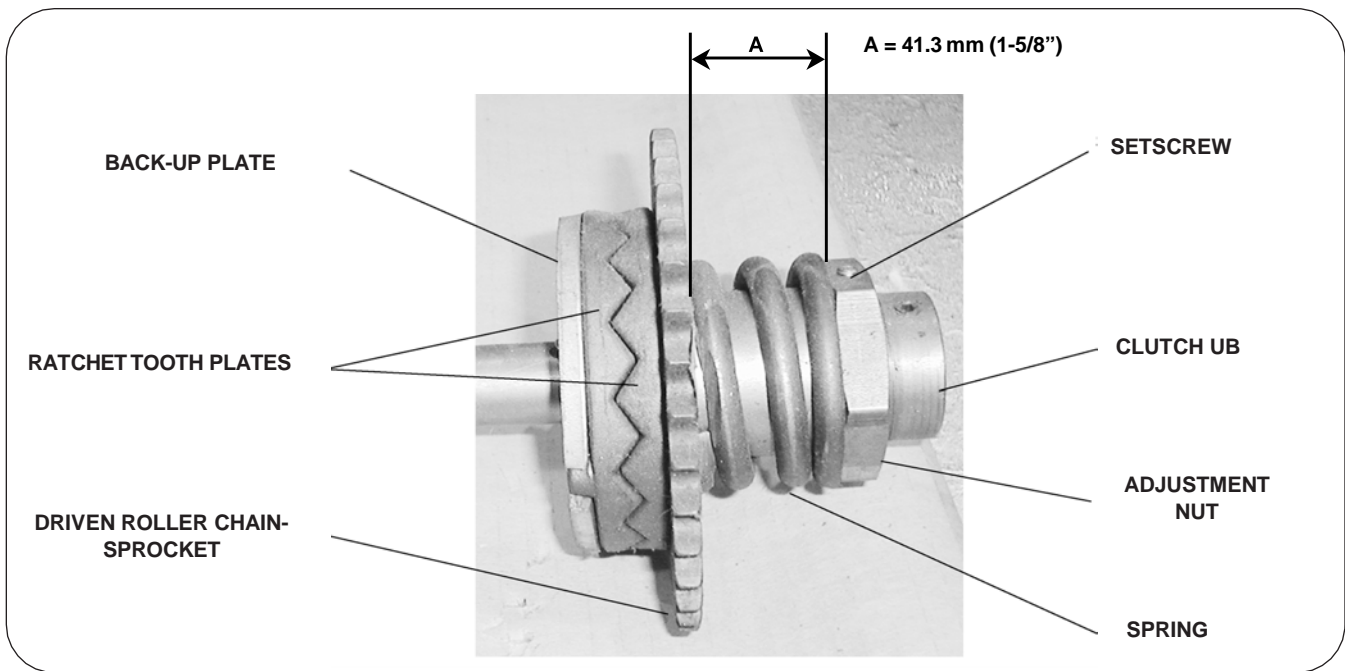

Figure 5. Ratchet Slip Clutch

should conform to NLGI No. 2 consistency, and should be free of chemical impurities such as free acid or alkali, and mechanical impurities such as dust, rust, metal particles, or abrasives. Add grease slowly until a slight bead forms between the seals.

Oil Lubrication

- The roller chain should be brushed with light-weight oil at regular intervals.

- The speed reducer on the direct drive unit is factory lubricated and sealed. It therefore requires no further lubrication.
- The indirect drive speed reducer may require periodic oil changes. Check instructions on the reducer.

NOTE: When changing oil in a double-reduction unit, be sure the primary and secondary chambers are both changed.

Table 2. Suggested Speed Reducer Lubricants

MANUFACTURER	AMBIENT TEMPERATURE	
	15 to 60°F	50 to 125°F
AMOCO	Worm Gear Oil	Cylinder Oil 680
CHEVRON	Cylinder 460X	Cylinder Oil - 680X
EXXON	Cylsestic TK460	Cylsestic TK680
GULF	Senate 460	Senate 680D
MOBIL	600W Super	Extra Hecla Super
SHELL	Valvata Oil J460	Valvata Oil J680
SUN	Gear Oil 7C	Gear Oil 8C
TEXACO	Honor Cyl. Oil	650T Cyl. Oil
UNOCAL	Steaval A	Worm Gear 140
Compound	AGMA 7	AGMA 8

TROUBLESHOOTING

PROBLEM	PROBABLE CAUSE	REMEDY
Unit does not operate.	Blown fuse.	Replace Fuse. Determine cause and correct.
	Tripped overload relay(s).	Determine cause and correct. Reset relay.
	Main disconnect off.	Turn main disconnect on.
	No power to line side of disconnect.	Determine reason for no power and correct.
Does not convey material up the incline.	Mis-application.	Contact factory.
	Chain / magnet not moving.	Drive chain broken. Repair or replace.
		Conveyor jammed. Clear jam.
Drive not functioning. Head-shaft pins sheared.		
Safety device tripping continuously (current limiter or ratchet slip clutch).	Chain or magnet broken.	Remove cover and inspect. Repair as necessary.
	Tensioning system broken or out of adjustment.	Remove cover and inspect. Repair as necessary.
	Cover plate depressed from impact of dropped heavy object.	Straighten cover plate. Check magnets for damage and replace as necessary.
Swarf / parts not being carried out.	Mis-application.	Contact factory.
	Cover plate bowed up, increasing air gap.	Straighten cover plate.

Notes

WARRANTY

Jorgensen Conveyors, Inc. guarantees the material of our manufacture against defects in material or workmanship under normal and proper use for one year in service or eighteen months from shipment, whichever occurs first. Material which we purchase can be guaranteed by use only to the extent of the original manufacturer's guarantee. We shall not be held liable for damages or delay caused by defective material, or contingent claims of any kind arising from loss of production owing to failure of shipment. Our obligation under this warranty is limited to furnishing new or replacing defective material without charge f.o.b. factory. No allowance will be made for repairs or alterations unless made with our written consent.

Caution should be used in the care and application of our products as the guarantee recited above does not apply where lack of proper maintenance or misapplication exists. We will not be liable for improper storage or handling of our products prior to placement in service.

The within equipment will be specifically designed and manufactured for and will be sold to purchaser for the sole purpose of transporting and conveying raw materials, work in process and finished goods of purchaser. Purchaser does hereby agree to exonerate, indemnify, defend and hold seller harmless of and from all loss, liability and damages which may be suffered by or asserted against the seller, and all costs and expenses which seller may incur because of any claim or claims which may be asserted against seller by any person for death or injury to anyone sustained while riding or attempting to ride upon said equipment.

JORGENSEN CONVEYORS, INC. • 10303 N. Baehr Road • Mequon, Wisconsin 53092-0156
P.O. Box 09156

Phone: 262-242-3089

Fax: 262-242-4382

Conveyor and Filtration Solutions
www.jorgensenconveyors.com